



## INSTALLATION AND OPERATION MANUAL

### MODELS: 4 Post Automotive Lift

**Item: T7000-4 / Model: QJY4030**

Maximum Lifting Capacity 7,000 lbs.

**Item: T7000-4NT / Model: QJY4030H**

Maximum Lifting Capacity 7,000 lbs.

**Item: T9000-4S / Model: QJY4040**

Maximum Lifting Capacity 9,000 lbs.

**Item: T9000-4ST / Model: QJY4040H**

Maximum Lifting Capacity 9,000 lbs.



**IMPORTANT SAFETY INSTRUCTIONS  
SAVE THESE INSTRUCTIONS**

Keep this operation manual near the machine at all times. Make sure all users read this manual.

### **! WARNING:**

#### **INSTRUCTIONS TO READ THE MANUAL(S) THOROUGHLY BEFORE INSTALLING, OPERATING, SERVICING, OR MAINTAINING THE LIFT.**

PLEASE READ THE ENTIRE CONTENTS OF THIS MANUAL, PRIOR TO INSTALLATION AND OPERATION. BY PROCEEDING WITH THE LIFT INSTALLATION AND OPERATION YOU AGREE THAT YOU FULLY UNDERSTAND THE FULL CONTENTS OF THIS MANUAL. THIS MANUAL MUST BE READ BY ALL USERS. FAILURE TO OPERATE THIS EQUIPMENT AS DIRECTED MAY CAUSE INJURY OR DEATH.

#### **ORIGINAL INSTRUCTIONS IN ENGLISH LANGUAGE**

#### **RECEIVING**

The shipment should be thoroughly inspected as soon as it is received. The signed Bill of Lading is acknowledgement by the shipping carrier as receipt of this product as listed in your invoice as being in a good condition of shipment. If any of these goods listed on this Bill of Lading are missing or damaged, do not accept goods until the shipping carrier makes a notation on the freight bill of the missing or damaged goods. Do this for your own protection.

### **! WARNING:**

Questions, problems, missing parts? Before returning to your retailer, call our customer service department at 1-888-448-6746 (1-888-44 TORIN), or [www.TORIN-USA.com](http://www.TORIN-USA.com) 8 a.m.- 5 p.m., PST, Monday-Friday.

Read carefully and understand all **ASSEMBLY AND OPERATION INSTRUCTIONS** before operating. Failure to follow the safety rules and other basic safety precautions may result in serious personal injury.

## READ THIS ENTIRE MANUAL BEFORE INSTALLATION & OPERATION BEGINS

### IMPORTANT

Before You Begin Register This Product.

For future reference, record the model name, model number, serial numbers, date of manufacture and purchase date of this product. You can find this information on the product.

Model Name	
Model Number	
ALI Gold Label Serial #	
Lift Serial #	
Date of Manufacture	
Date of Purchase	
Power Unit Model #	
Power Unit Date of Mfg.	
Power Unit Serial #	

Save the receipt, warranty and these instructions. This information is required when calling for parts or warranty issues. Warranty is non-transferable. To be able to make a claim under a written warranty, the manufacturer requires you to register the product by filling in and returning a warranty card or by registering the product online at [www.tcegarage.com](http://www.tcegarage.com).

**TO VALIDATE YOUR LIFT WARRANTY**  
**Register online before first use at [www.TCEGARAGE.com](http://www.TCEGARAGE.com)**

## SAVE THESE INSTRUCTIONS

### OWNER / USER RESPONSIBILITY

#### DO NOT OPERATE OR REPAIR THIS PRODUCT WITHOUT READING THIS MANUAL.

Read and follow the safety instructions. Keep Instructions readily available for operators. Make certain all operators are properly trained and understand how to safely and correctly operate the product. By proceeding you agree that you fully understand and comprehend the full contents of this manual. Failure to operate this product as intended may cause injury or death. The manufacturer is not responsible for any damages or injury caused by improper use or neglect. Allow product operation only with all parts in place and operating safely. Use only genuine replacement parts. Service and maintain the product only with authorized or approved replacement parts; negligence will make the product unsafe for use and will void the warranty. Carefully inspect the product on a regular basis and perform all maintenance as required. Store these instructions in a protected dry location. Keep all decals on the product clean and visible. Do not modify and/or use for any application other than that for which this product was designed. If you have any questions relative to a particular application, DO NOT use the product until you have first contacted the distributor or manufacturer to determine if it can or should be performed on the product.

## SHIPPING DAMAGE CLAIMS

Once the equipment/product has been shipped, bill of sale passes to the Purchaser. Materials damaged in shipment claims must be made by the Purchaser against the Freight Carrier at the time of shipment arrival. Any freight damage must be noted on the freight bill before signing and reported to the freight carrier with a freight claim established. Manufacturer is not responsible for freight claims. Identify the components and check for shortages. If shortages are discovered, please contact the Distributor / Sales Representative in your area for service. It is the customer's responsibility to arrange for unloading of products shipped.

## SHIPPING FREIGHT

This item is shipped via "truck freight" (common carrier or flat-bed, not UPS). Truck freight companies do NOT require their drivers to unload shipments. An additional "Lift Gate" fee will apply if the driver unloads the merchandise. The shipping carrier will call and schedule delivery, at which time, you may request a "Lift Gate" (provided the weight and dimensions of the product fits the criteria for lift gate service) and arrange payment with the carrier for that service.

## GENERAL SAFETY RULES

 **WARNING:** Read and understand all instructions. Failure to follow all instructions listed below may result in serious injury.

 **CAUTION:** Do not allow persons to operate or assemble this product until they have read this manual and have developed a thorough understanding of how the product works.

 **WARNING:** The warnings, cautions, and instructions discussed in this instruction manual cannot cover all possible conditions or situations that could occur. It must be understood by the operator that common sense and caution are factors that cannot be built into this product, but must be supplied by the operator.

## HAZARD DESCRIPTIONS

Use alertness and prudence in a hazardous situation; care; wariness.

Identify the hazard levels used in this manual with the following definitions and signal words:

 **DANGER:**  
Immediate hazards which will result in severe liability or exposure to personal injury or death.

 **WARNING:**  
Hazards or unsafe practices which could result in severe personal injury or death.

 **CAUTION:**  
Hazards or unsafe practices which may result in personal injury, product or property damage.

## IMPORTANT INFORMATION:

This lift is designed for indoor use only, and should not be installed in a pit or uneven surface. Manufacturer recommends the floor on which the lift is to be installed must be 6-1/4" inch minimum thickness concrete, with a minimum compressive strength of 3000 psi, and reinforced with steel bar, and a minimum edge distance of 8 inches. (Contact your building architect for information before installing on Pre-stressed concrete.)

The lift has specific electrical requirements as described in the Installation Instructions section of this manual. This lift has a minimum ceiling height requirement as described in the Installation Instructions section of this manual. Failure by the owner to provide the recommended shelter, mounting surface, electrical supply, and ceiling height could result in unsatisfactory lift performance, property damage, or personal injury.

# IMPORTANT SAFETY INSTRUCTIONS



**WARNING:** When using your garage equipment, basic safety precautions should always be followed, including the following:

1. Read all instructions. Study, understand, and follow all instructions before operating this device.
2. Care must be taken as burns can occur from touching hot parts.
3. Do not operate equipment, with a damaged cord or if the equipment has been dropped or damaged - until it has been examined by a qualified service person.
4. Do not let a cord hang over the edge of the table, bench, or counter or come in contact, with hot manifolds or moving fan blades.
5. If an extension cord is necessary, a cord, with a current rating equal to or more than that of the equipment should be used. Cords rated for less current than the equipment may overheat. Care should be taken to arrange the cord so that it will not be tripped over or pulled.
6. Always unplug equipment from electrical outlet when not in use. Never use the cord to pull the plug from the outlet. Grasp plug and pull to disconnect.
7. Let equipment cool completely before putting away. Loop cord loosely around equipment when storing.
8. To reduce the risk of fire, do not operate equipment in the vicinity of open containers of flammable liquids (gasoline).
9. Adequate ventilation should be provided when working on operating internal combustion engines.
10. Keep hair, loose clothing, fingers, and all parts of body away from moving parts.
11. To reduce the risk of electric shock, do not use on wet surfaces or expose to rain.
12. Use only as described in this manual. Use only manufacturer's recommended attachments.
13. ALWAYS WEAR SAFETY GLASSES. Everyday eyeglasses only have impact resistant lenses; they are not safety glasses.
14. To reduce the risk of injury, close supervision is necessary when this product will be used around children. (Pertains to cabinets only.)
15. To reduce the risk of injury, never overload the drawers or shelves. Refer to loading instructions.
16. To reduce the risk of electric shock or fire, never overload receptacles. Refer to markings for the proper load on receptacles.
17. Do not exceed rated capacity.
18. Use only on hard, level surfaces with less than 3 degrees of slope.
19. Do not move or dolly the vehicle while on the lift.
20. Lift only on areas of any vehicle as specified by the vehicle manufacturer.
21. No alterations shall be made to this product.
22. Only attachments and/or adapters supplied by the manufacturer shall be used.
23. Do not get under or allow anyone under the vehicle until it has been supported with auxiliary jack stands on both the front and rear of the vehicle.
24. Center load on lifting arms and saddles prior to lifting.
25. Secure vehicle to ensure no shifting, movement, or tipping will occur when performing maintenance on any vehicle.
26. Verify that safety locks are engaged on the arms and lifting carriages before performing any work.
27. NEVER use lift with a motorcycle, lawn mower, or lawn tractor.
28. Do not use this product for any use other than the manufacturer specified usage. Failure to heed these warnings may result in personal injury and/or property damage. The distributor is not responsible for any damages or injury caused by improper use or neglect.
29. Do not use wood blocks or any other non-approved load sustaining devices or any other non-approved lifting devices for a means of lifting a vehicle, stabilizing, securing, spacing, adding additional height, or load being raised. The manufacturer only warrants loads to be sustained by adapters or accessories validated by the manufacturer. Failure to heed these warnings may cause injury or death.
30. Do not adjust power unit pressure relief valve, any tampering will void warranty and may cause catastrophic failure. Failure to heed these warnings may result in injury or death.

## IMPORTANT SAFETY CONSIDERATIONS

To maintain the product and user safety, the responsibility of the owner is to read and follow these instructions.

- Inspect the product for proper operation and function before each use.
- Do not modify the product in any way. Unauthorized modification may impair the function and/or safety and could affect the life of the equipment. There are specific applications for which the product was designed.
- Always check for damaged or worn out parts before using the lift. Broken parts will affect the equipment operation. Replace or repair damaged or worn parts immediately.
- Keep instructions readily available for equipment operators.
- Make certain all equipment operators are properly trained; understand how to safely and correctly operate the unit.
- Allow unit operation only with all parts in place and operating properly.
- Use only genuine replacement parts.
- Service and maintain the unit only with authorized or approved replacement parts; negligence will make the product unsafe for use and void the warranty.
- Carefully inspect the unit on a regular basis and perform all maintenance as required.
- Keep all decals on the unit clean and visible.



### **GENERAL SAFETY INSTRUCTIONS:**

**Training** - Do not allow anyone who has not read this manual, and/or does not understand the requirements to use the product.

**Spectators** - Do not allow bystanders around the lift or under the load supported. Do not allow anyone in a vehicle while the lift is in use or is supporting a load. Keep all bystanders away from lift when in use.

**Operators** - Not for use by children or people with reduced mental capacity. Not for use under the influence of drugs or alcohol.

**Inspection** - Inspect the product carefully before each use. Ensure the product is not damaged, excessively worn, or missing parts. Do not use the lift unless it is properly lubricated. Using a lift that is not in good clean working condition or properly lubricated may cause serious injury.

## SAFETY STICKER IDENTIFICATION

Use care when identifications and markings are on lift. These identifications are put in place to help with your safety and the safety of others. Always use caution when working around vehicle lift. Replace labels if damaged or torn.

## WIRE ROPE INSPECTION LABEL

(LABEL TO BE ATTACHED BY MANUFACTURER)

# WARNING

**WIRE ROPE INSPECTION AND MAINTENANCE**

Equalizing and Lifting Cables should be replaced every three years when visible signs of damage are apparent. DO NOT USE THE LIFT WITH DAMAGED OR WORN CABLES.

- Wire Rope WILL FAIL if worn-out, overloaded, misused, damaged, improperly maintained or abused. Wire rope failure may cause serious injury or death!
- Protect yourself and others:
- ALWAYS INSPECT wire rope for WEAR, DAMAGE or ABUSE BEFORE USE.
- NEVER USE wire rope that is WORN-OUT, DAMAGED or ABUSED.
- NEVER OVERLOAD a wire rope.
- INFORM YOURSELF: Read and understand manufacturer's literature or "Wire Rope and Wire Rope Sling Safety Bulletin"

• Wire Rope should be maintained in a well-lubricated condition at all times. Wire rope is only fully protected when each wire strand is lubricated both internally and externally. Excessive wear will shorten the life of the wire rope. The manufacturer suggests using a wire rope lubricant that penetrates to the core of the wire rope, providing long term lubrication. All wire rope, sheaves and guide rollers in continuous service should be observed during normal operation and visually as per the scheduled maintenance. A complete and thorough inspection of all ropes in use must be made as below and all rope which has been idle for a period of a month or more should be given a thorough inspection before it is put back into service. Factors such as abrasion, wear, fatigue, corrosion, improper winding and kinking are often of greater significance in determining if a wire rope is usable.

**Recommended Lubrication Product:**  
 A high grade penetrating lubricant for wire rope, chain and cable that contain a petroleum solvent that carry the lubricant into the core of the wire rope, then evaporates, leaving behind a heavy lubricating film to protect and lubricate each strand. A penetrating lubricant is essential in any lubrication program as most wire rope fails from the inside out.  
 Check all guide rollers, sheaves and hardware that are in operational contact are visually checked for wear and lubrication

For additional information and instructions see the USER INSTRUCTION MANUAL provided with the lift.

**Failure to read, understand, and follow these instructions may cause death or serious injury. Read and understand these instructions before using the lift.**

## WIRE ROPE INSPECTION LABEL

(LABEL TO BE ATTACHED BY MANUFACTURER)

		Torin Commercial Equipment	
Model		Cable Lengths	
		A -	mm
Lifting Capacity		B -	mm
lb                      kg		C -	mm
Manufactured Date		D -	mm
		Cable Diameter                      mm	
Serial Number		<b>60 Hz usage</b>	
<b>Manufacturer recommends using a 32-amp circuit for operating lift</b>			
Registered by TORIN Inc. 4355 E. Brickell St. Ontario, California 91761 USA			
Phone: 1-909-390-8588      Fax: 1-909-390-8618			
Designed in USA, Made in China			

**POWER UNIT WARNING LABELS  
(LABEL TO BE ATTACHED BY MANUFACTURER)**

 **CAUTION**   
**PRECAUCIÓN / ATTENTION**

**RISK OF ELECTRICAL SHOCK.**  
Do Not Remove Cover. No User-Serviceable Parts Inside.  
Refer Servicing To Qualified Service Personnel.  
Disconnect All Sources Of Supply Prior To Servicing.  
RIESGO DE DESCARGA ELÉCTRICA.  
No retire la cubierta. Sin usuario pueda reparar piezas en el interior. La reparación al personal de servicio cualificado. Desconecte todas las fuentes de para la revisión de la oferta.  
RISQUE DE CHOC ÉLECTRIQUE.  
Ne pas retirer le boîtier. No User-réparable Pièces Inside. TECHNICIENS QUALIFIÉS du personnel de service. Débranchez toutes les sources de Fourniture Avant l'entretien.

DO NOT USE BELOW GARAGE FLOOR OR GRADE LEVEL.  
*NO DEBE UTILIZARSE DEBAJO DEL PISO DEL GARAGE O DEL GRADO .*  
NE PAS UTILISER A UN NIVEAU INFÉRIEUR A CELUI DU PLANCHER DU GARAGE OU DU SOL.

 **WARNING/ADVERTENCIA/ATTENTION**

Hydraulic oil should only be changed when equipment is fully lowered. Use only recommended ISO AW32 or AW46 hydraulic oils. Oil must be changed after the first week of operation and once every 12 months or as needed.

*El aceite hidráulico debería cambiarse únicamente cuando el equipo ha sido completamente descendido. Utilice únicamente aceites hidráulicos recomendados ISO AW32 o AW46. El aceite debe cambiarse después de la primera semana de funcionamiento y una vez cada 12 meses o cuando sea necesario.*

L'huile hydraulique ne devrait être changée que lorsque l'équipement est complètement abaissé. Utilisez seulement des huiles hydrauliques recommandées ISO AW32 ou AW46. L'huile doit être changée après la première semaine de fonctionnement et tous les 12 mois ou au besoin.

YXBS-01 REV151022

Power Unit Hydraulic Oil Label

**Press Button (ON)**  

**Press Lever to Lower**  

 **DANGER / PELIGRO**

Risk Of Explosion. This equipment has internal arcing or sparking parts which should not be exposed to flammable vapors. This Equipment Has Internal Arcing Or Sparking Parts Which Should Not Be Exposed To Flammable Vapors. It Should Not Be Located In A Recessed Area Or Below Floor Level.  
*Risque d'explosion. Existe riesgo de explosión. Este equipo tiene partes internas de cebado o de producción de chispas que no deberían estar expuestas a vapores inflamables. No debe ser situado en una zona rebajada o por debajo del nivel de piso.*  
Cet équipement a courber interne ou pièces d'étincellement qui ne devraient pas être exposés aux vapeurs inflammables. Il ne devrait pas être situé dans un secteur enfoncé ou au-dessous du niveau de plancher.

 **WARNING/ADVERTENCIA/ATTENTION**

Always allow a minimum 2-second delay between motor starts. Failure to comply may cause switch and/or motor to burnout. This could cause serious damage to the equipment and/or personal property. Power unit must be wired by a qualified electrician. This power unit should be located at least 18 inches (460 mm) above the floor.  
*Asigne siempre un lapso mínimo de 2 segundos entre arranques del motor. Si no se respetara este tiempo podrían recalentarse el interruptor y/o el motor. Esto podría provocar serios daños al equipo y/o otros daños materiales. El cableado de la unidad de energía debe ser realizado por un electricista calificado. Esta unidad de energía debería estar ubicada al menos a 18 pulgadas (460 mm) sobre el nivel del suelo.*  
Il faut toujours prévoir un délai minimum de 2 secondes entre les démarrages du moteur. Ne pas respecter ce délai pourrait provoquer le grillage de l'interrupteur et/ou du moteur. Ceci pourrait gravement endommager votre équipement et/ou provoquer des dommages matériels. L'installation électrique de l'unité d'alimentation doit être faite par un électricien qualifié. Cette unité d'alimentation devrait être placée au moins 18 pouces (460 mm) au-dessus du sol.

MBS-01 REV160527

**CAUTION**  
(1) MINIMUM CIRCUIT AMPACITY OF CONDUCTOR IS 15 A  
(2) IF CONNECTED TO A CIRCUIT PROTECTED BY FUSES, USE TIME-DELAY FUSE MARKED "D"

**PRECAUCIÓN**  
(1) CIRCUITO DE MÍNIMO AMPACIDAD CONDUCTOR ES DE 15 A  
(2) SI ESTÁ CONECTADO A UN CIRCUITO O PROTEGIDO POR FUSIBLES, USE ALARMAS DE RETARDO FUSE EN LA LETRA "D"

**ATTENTION**  
(1) COURANT ADMISSIBLE MINIMAL DE LA DERIVATION 15 A  
(2) IF RELIÉ À UN CIRCUIT PROTÉGÉ PAR DES FUSIBLES, TIME-DELAY UTILISATION FUSE MARQUÉ "D"

 **CAUTION**  
If connected to a circuit protected by fuses, use time delay fuses with this equipment.

**USE SUPPLY WIRES SUITABLE FOR 105°C (221°F)  
USE CABLES DE ALIMENTACIÓN CONVENIENTE PARA 105°C (221°F)  
EMPLOYER DES FILS D'ALIMENTATION POUR 105°C (221°F)**

**OPERATING INSTRUCTION LABEL**  
(LABEL TO BE ATTACHED BY MANUFACTURER)

**SAFETY WARNINGS**

4-Post rev190411

**NOTICE**

**ONLY AUTHORIZED PERSONNEL SHALL OPERATE THIS EQUIPMENT**

**NOTICE**

Read and understand all instructions.



Refer to the vehicle manufacturer recommended lifting points, before lifting any vehicle on the lift or supplementary lifting devices on the lift.

**DANGER**

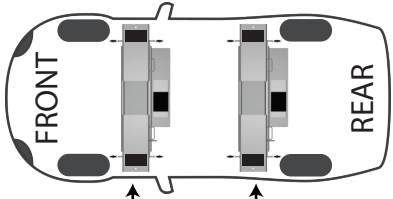

FRONT REAR

SUPPLEMENTARY LIFTING DEVICES

NEVER lift any vehicle in any manner other than lifting and entire vehicle. Vehicles are NOT to be raised with a partial vehicle on the lift.

**DANGER**

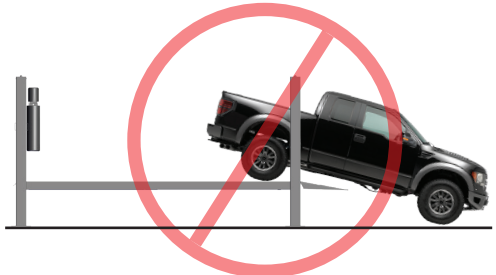

**DANGER**

DO NOT override or tamper with safety devices or operating controls. They are installed for your safety. Failure to comply will result in death and serious injury.

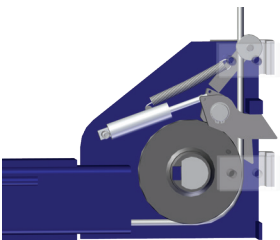

**WARNING**

INSPECT THE LIFT DAILY.

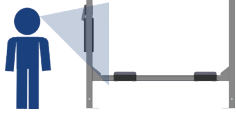

DO NOT operate lift that is damaged or under repair.

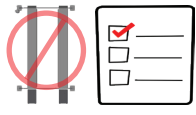

**WARNING**

Clear area if vehicle is in danger of falling.



**WARNING**

Keep feet clear when lowering lift.

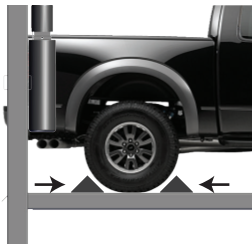
**WARNING**

ALWAYS Use chocks or a blocking device on vehicle before raising lift.



**WARNING**

**PINCH POINT.** Keep all body parts and clothing clear of moving parts. Follow lockout procedure before cleaning or servicing.

DO NOT PAINT OVER THIS LABEL. REPLACE IF DAMAGED OR LOST.

# OPERATING INSTRUCTION LABEL (LABEL TO BE ATTACHED BY MANUFACTURER)

## OPERATING INSTRUCTIONS

4-Post rev190411

**WARNING:** Read and understand all instructions. Failure to follow all instructions listed below may result in serious injury.

**CAUTION:** Do not allow persons to operate or assemble this product until they have read this manual and have developed a thorough understanding of how the product works.

**WARNING:** The warnings, cautions, and instructions discussed in this instruction manual cannot cover all possible conditions or situations that could occur. It must be understood by the operator that common sense and caution are factors that cannot be built into this product, but must be supplied by the operator.

### ONLY AUTHORIZED PERSONNEL ARE TO OPERATE LIFT.

BEFORE OPERATING LIFT READ OPERATING MANUAL AND SAFETY DOCUMENTS SUPPLIED WITH THE LIFT. ONLY TRAINED and AUTHORIZED PERSONNEL should operate the lift. Do not allow customers or unauthorized personnel to operate the lift or remain in the lift area during use.

**WARNING THIS MOTOR HAS INTERNAL ARCING AND SPARKING PARTS. TO MINIMIZE THE RISK OF EXPLOSION, DO NOT EXPOSE TO FLAMMABLE VAPORS.** Use only recommended ISO AW32 or AW46 hydraulic oils.

Power Unit Motor duty cycle is one full lifting operation 10 minutes, this will include the lifting and lowering time.

**OPERATING CONDITIONS:** Lift is not intended for outdoor use and has an operating temperature rating between 40°F – 105°F (4°C - 41°C)

**DO NOT** install on asphalt or other similar unstable surface. Columns are supported only by anchoring to concrete floors. Manufacturer will not be held responsible for any concrete that may not meet slope requirements and will not be responsible for any charges relating to new concrete slabs pouring or leveling or damage.

**INSPECT THE LIFT DAILY.** Do not operate if potential problems have been identified or lift malfunctions. Do not operate if lift has damaged or broken components. Check all moving parts for any type of damage that may affect misalignment or operation of lift.

Inspect all anchors bolts and retighten if necessary. Re-torque as needed. See installation manual for instructions.

**ALWAYS** ensure the safeties are engaged before any attempt is made to work on or near the vehicle.

**DO NOT** operate the lift while batteries are charging

**DO NOT** raise/lower only one side of the vehicle

**NEVER** leave lift in elevated position unless the safeties are engaged.

**NEVER** operate the lift with any person or equipment below the vehicle.

**DO NOT** attempt to work on the vehicle or go near vehicle when lift is being raised or lowered.

**ALWAYS** remain clear of lift when raising or lowering vehicle.

**NEVER** exceed the rated lift capacity.

**ALWAYS** position lifting arms, ramps, adapters and accessories properly out of the way before pulling the vehicle into or out of the bay. Failure to do so could damage the vehicle and/or the lift.

## TO RAISE THE LIFT:

1. Adjust the vehicle to be positioned within the runway ramps and the center of gravity midway between the runways.
2. Press the power “on” button.
3. A clicking sound will be heard as the lift raises. These are the carriage locks that will securely hold a vehicle.
4. Once the desired height has been achieved slightly raise the carriage just above the last engaged latch position and slowly lower the load on the safety locks using the hydraulic lowering valve.
5. Verify that all 4 Safety Carriage locks have been engaged before beginning work or walking under the lift.
6. Use of jack stands or other load supporting devices will help in preventing load shifts. Manufacturer suggests that high position hoist stands or other load supporting devices are used at all times for additional security. Use additional lifting equipment or stands when removing or installing heavy vehicle components.
7. Make sure the vehicles center of gravity is always safe before raising vehicle. Any points of contact on vehicle that are not in good contact with lift or with lifting pads should always be double checked. Always make sure the vehicle is secure before lifting. Always use only your vehicle manufacturers’ recommended lifting points.

## TO LOWER THE LIFT:

8. Lower any extension adapters or any supplementary lifting devices on the lift, and move out of the lowering path.
9. To lower the lift, first raise the lift to clear the safety latches, press the power “on” button, slightly raise the carriage just above the last engaged latch position. The carriages should now be in the free UN-LOCKED position.
9. GENTLY and SLOWLY press the pneumatic air release button slowly while simultaneously pressing the hydraulic lowering valve.
- A. **Simultaneously with the Safety Carriage Locks levers in the UN-LOCKED Position and by pressing the lowering control valve on the power unit, and the pneumatic air release button lower the lifting carriages slowly.**
- B. **The runways will begin to lower the load.**
- C. **Verify all locks have cleared at the first lock together, before fully lowering the lift.**
10. Lower the lift slowly until reach the lowest retracted position.
12. Place any arm extension adapters on column storage brackets.

# TORIN™

### ▲ WARNING: Questions, problems, missing parts?

Before returning to your retailer, call our customer service department at 1-888-448-6746 (1-888-44 TORIN), 8 a.m. - 5 p.m., PST, Monday-Friday. [www.TORIN-USA.com](http://www.TORIN-USA.com)

Read carefully and understand all ASSEMBLY AND OPERATION INSTRUCTIONS before operating. Failure to follow the safety rules and other basic safety precautions may result in serious personal injury.

DO NOT PAINT OVER THIS LABEL. REPLACE IF DAMAGED OR LOST.

## **WARNING PARAGRAPH**

The operation manual should be kept near the equipment at all times.

Please be sure to make sure that ALL USERS read this manual before use and operation.

Please read carefully the entire contents of this manual prior to installation and operation.

By proceeding you agree that you fully understand and comprehend the full contents of this manual.

Failure to operate this equipment as directed may cause injury or death.

The manufacturer is not responsible for any damages or injury caused by improper use or neglect.

## **IMPORTANT INFORMATION:**

Read this manual thoroughly before installing, operating, or maintaining this lift.

This lift is designed for indoor use only, and should not be installed in a pit or uneven surface.

The floor on which the lift is to be installed must be 6-1/4" inch minimum thickness concrete, with a minimum compressive strength of 3000 psi, and reinforced with steel bar.

(Contact your building architect for information before installing on pre-stress concrete.)

The lifts have specific electrical requirements as described in the Installation Instructions section of this manual.

This lift has a minimum ceiling height requirement as described in the Installation Instructions section of this manual.

Failure by the owner to provide the recommended shelter, mounting surface, electrical supply, and ceiling height could result in unsatisfactory lift performance, property damage, or personal injury.

## **SHIPPING DAMAGE CLAIMS**

Once the equipment/product has been shipped, bill of sale passes to the Purchaser. Materials damaged in shipment claims must be made by the Purchaser against the Freight Carrier at the time of shipment arrival. Any freight damage must be noted on the freight bill before signing and reported to the freight carrier with a freight claim established. Manufacturer is not responsible for freight claims. Identify the components and check for shortages. If shortages are discovered, please contact the Distributor / Sales Representative in your area for service.

It is the customers responsibility to arrange for unloading of products shipped.

## **HAZARD DESCRIPTIONS**

Identify the hazard levels used in this manual with the following definitions and signal words:



Immediate hazards which will result in severe liability or exposure to personal injury or death.



Hazards or unsafe practices which could result in severe personal injury or death.



Hazards or unsafe practices which may result in personal injury, product or property damage. Use alertness and prudence in a hazardous situation; care; wariness.

## INTENDED USE

This two-post car lift is designed to lift and raise light duty vehicles under 10,000-lbs. Our 2 post car lifts offer variable lifting configurations, for unobstructed floor space while repairing vehicles.

## TECHNICAL SPECIFICATIONS





#	Key Specs	T9000-4ST	T9000-4S	T7000-4N	T7000-4NT
		QJY4040H	QJY4040	QJY4030	QJY4030H
		(in) (lbs)	(in) (lbs)	(in) (lbs)	(in) (lbs)
	Lift Capacity	9,000-lbs	9,000-lbs	7,000-lbs	7,000-lbs
A -	Overall length	238.6	200.48	200.48	238.6
A1 -	Overall Length Plate to Plate	209.1	175.03	175.03	209.1
B -	Overall width	131.7	131.7	107.51	107.5
C -	Overall height	105	92	92	105
D -	Overall height of posts	101.58	87.8	87.8	101.58
E -	Max. lifting height to top of runways	87.8	75.5	75.5	87.8
F -	Max. clearance under runways on top of lock	82.5	69	69	82.5
G -	Minimum ground clearance	5.5	5.5	5.5	5.5
H -	Approach ramp length	34.5	34.5	34.5	34.5
I -	Runway dimensions length	199.2	166	166	199.2
J -	Runway dimensions width	18.92	18.92	18.92	18.92
K -	Runway dimensions height	4.68	4.68	4.68	4.68
L -	Outside width of both runways (Adjustable)	76 / 81.9	76 / 81.9	69.4 / 75.6	69.4 / 75.6
M -	Clearance between runways (Adjustable)	38.2 / 44.1	38.2 / 44.1	31.6 / 37.9	31.6 / 37.9
N -	Overall width outside of posts	117	117	102	102
O -	Max. clearance between posts	106.9	106.9	92	92
P -	Ramp gauge of steel	1/4"	1/4"	1/4"	1/4"
Q -	Post dimensions length	6	6	6	6
R -	Post dimensions width	5	5	5	5
	- Locking positions (qty.)	18	13	13	18
	- Time of full rise (seconds)	70	60	60	70
	- Motor phase(s)	1 Phase	1 Phase	1 Phase	1 Phase
	- Voltage	110V(26AMP)	110V(26AMP)	110V(26AMP)	110V(26AMP)
	- Htz	60	60	60	60
	- Manufacturer warranty	1Year Limited	1 Year Limited	1 Year Limited	1 Year Limited

Safe Operating Temperature is between 40°F – 105°F (4°C - 41°C)

**Manufacturer recommends using a 32-amp circuit for operating lift**

## FASTENER TORQUE RECOMMENDATIONS

Values are stated in foot pounds (ft-lbs)

HHCS SHCS CSCS (SAE)	HHCS SHCS CSCS (Metric)					
		(SAE) Grade 2 (Metric) Class 5.8	(SAE) Grade 5 (Metric) Class 8.8	(SAE) Grade 8 (Metric) Class 10.9	Socket Head Cap Screw Class 12.9	Socket Head Cap Screw Class 12.9
1/4-20	M6 X 1.0	6	10	14	7.1	11.6
5/16-18	M8 X 1.25	12	19	29	17	29
3/8-16	M10 X 1.50	20	33	47	34	57
7/16-14	NA	32	54	78	NA	NA
1/2-13	M12 X 1.75	47	78	119	59	99
9/16-12	M14 X 2.00	69	114	169	94	158
5/8-11	M16 X 2.00	96	154	230	146	250
3/4-10	M18 X 2.50	155	257	380	210	341
7/8-9	M22 X 2.5	206	382	600	NA	559

**M16 Anchor Bolts**

**150 ft-lbs (for Simpson Strong-Bolt® 2 Wedge Anchor provided)**

## CONCRETE FOUNDATION ANCHORING SPECIFICATIONS AND REQUIREMENTS

Manufacturer recommends installation on 2-Post Models use a concrete pad 6 Inch Min. Thickness / 3,000 PSI (4,000 PSI Recommended)

Before installing your new lift, check the following:

**Select Lift Location:** Always use architects building plans when available. Check layout dimension against floor plan requirements making sure that adequate space is available.

**Floor Requirements:** The lift should be located on a relatively level floor of less than 3 degrees' slope. If slope is questionable, consider a survey of the site and/or the possibility of pouring a new level concrete slab. Failure to do so could cause personal injury or death.

**Ceiling Requirements:** The area where the lift will be located should be free of overhead obstructions such as heaters, building supports, electrical lines, etc....

**Defective Concrete:** Visually inspect the site where the lift is to be installed and check for cracked or defective concrete. If site is in question, contact a local inspection agency before installing lift.

**DO NOT** install on asphalt or other similar unstable surface. Columns are supported only by anchoring to concrete floors.

Manufacturer will not be held responsible for any concrete that may not meet slope requirements and will not be responsible for any charges relating to new concrete slabs pouring or leveling or damage.

## IMPORTANT INFORMATION AND GENERAL NOTES FOR EXPANSION ANCHORS

### General Instructions for Installing Concrete Anchors

- These general instructions for the installer are provided to ensure the proper selection and installation of Anchor Products and must be followed carefully. These general instructions are in addition to the specific design and installation instructions and notes provided for each particular product, all of which should be consulted prior to and during the installation Anchor Products.
- Use proper safety equipment.
- Most concrete mixes are designed to obtain the desired properties within 28 days after being cast (28-day cure).
- Concrete shall have compression strength of at least 3,000 PSI and a minimum thickness of 6-1/4" in order to achieve a minimum anchor embedment. NOTE: When using the standard supplied M16x150 anchors; if the top of the anchor exceeds 2 1/4" above the floor grade you DO NOT have enough embedment.
- Maintain a 8" minimum distance from any slab edge or seam. Hole to hole spacing should be a minimum 6 1/2" in any direction. Hole depth should be a minimum of 6-1/4".
- Do not modify Mechanical Wedge Anchor products. The performance of modified products may be substantially weakened. Manufacturer will not warrant or guarantee the performance of such modified products.
- Do not alter installation procedures from those set forth in this Manual.
- Drill holes for mechanical anchors with carbide-tipped drill bits meeting the diameter requirements of ANSI B212.15. A properly-sized hole is critical to the performance of mechanical anchors.
- Rotary-hammer drills with light, high frequency impact is recommended for drilling holes.
- Do not use excessively worn bits or bits which have been incorrectly sharpened.
- Please note that the use of oversized holes' is NOT permitted for anchoring any lift. DO NOT USE Anchor Adhesive to fill spacing of oversize holes'. Move lift location or fill holes with Anchor Adhesive and Re-drill to correct Hole Specification. (See manufacturer for proper anchor adhesive curing times.)

# EXPANSION ANCHOR INSTALLATION INSTRUCTIONS M16x150

Anchor size is same as drill bit size ( 16mm )

Use a hammer drill with a Carbide tip, 16mm diameter, solid drill bit. The bit tip diameter should be to ANSI Standard B212.15-1994. The Simpson-Tie Strong Bolt 2 wedge anchor is used to resist static, wind and seismic tension and concrete loads in cracked and uncracked concrete applications, with a compressive strength of 3,000psi to 8,500psi. Supports Compliance with 2015, 2012, 2009, and 2006, 2003 International Building Code (IBC); and International Residential Code (IRC). The Strong-Bolt 2 wedge anchors are torque-controlled, mechanical expansion anchors consisting of an anchor body, expansion clip, nut, and washer.

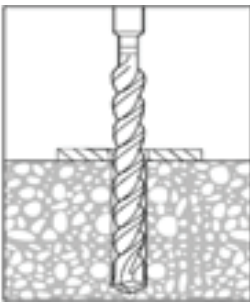
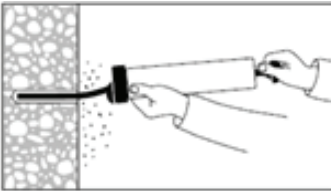
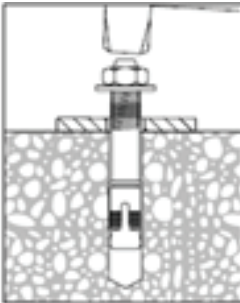
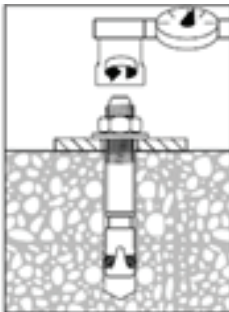
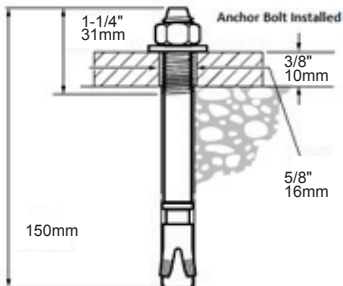
<p><b>Step 1</b></p> 	<p>Hammer Drill a hole to the same nominal diameter as the expansion anchor. The hole depth must exceed the anchor embedment at least 1/4". Use the baseplate as a drilling template to ensure proper anchor locations. (Drill completely through the concrete floor in case movement of the lift is required.)</p>
<p><b>Step 2</b></p> 	<p>Clean hole completely. Remove dirt and dust with the use of a shop vac. or an air compressor.</p>
<p><b>Step 3</b></p> 	<p>Assemble the flat washer and nut flush on the anchor bolt. Drive the expansion anchor into the hole using a hammer. If shimming is required, make sure to leave threads exposed for proper shimming.</p>
<p><b>Step 4</b></p> 	<p>Tighten the nut to the recommended installation torque.</p>
<p><b>Step 5</b></p> 	<p>Installation complete.</p>

Do not disturb, bolt up, or apply load to adhesive anchors prior to the full cure of any adhesive. Metal anchors and fasteners will corrode and may lose load-carrying capacity when installed in corrosive environments or exposed to corrosive materials. There are many environments and materials which may cause corrosion including ocean salt air, fire-retardants, fumes, fertilizers, preservative-treated wood, dissimilar metals, and other corrosive elements. **Finished Diameters for Rotary and Rotary Hammer Carbide Tipped Concrete Drills per ANSI B212.15**

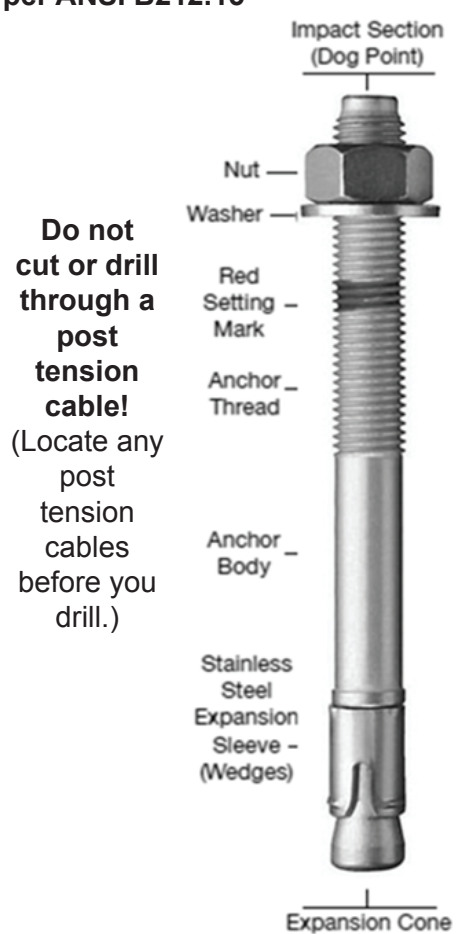

## PRE-INSTALLATION PROCEDURES

Before beginning your installation make sure you read the installation manual and insure all instructions and safety guidelines are fully understood. Check that all component parts are accounted for. Locate the installation area, identify the center line of the bay and mark the floor. Also mark the center of bay entrance door. Connect these two points with a short chalk line in the area where lift will be located. Draw a second chalk line at 90° to locate the positions of both lift columns. (Refer to lift dimensions on this page)

**Keep this manual with lift at all times.**

**DO NOT INSTALL LIFT ON ASPHALT OR ANY OTHER SURFACE THAN A CONCRETE FLOOR CONFORMING TO THE MINIMUM REQUIREMENTS DETAILED IN THIS MANUAL. DO NOT INSTALL THIS LIFT ON CONCRETE WITH SEAMS OR CRACKS OR DEFECT. IF YOU HAVE ANY QUESTIONS AND CONCERNS WITH THE LIFT LOCATION SELECTED CONTACT YOUR LOCAL ARCHITECT.**



**Use safety protective clothing and protective wear when installing lift.**

### Installation Tools Required:

- 25ft. Measuring tape
- Chalk line and chalk
- Heavy duty metal wire cutters
- 3 ft. Crow bar
- Full set of metric wrenches and ratchet set
- Full set SAE wrenches and ratchet set
- Full set metric and SAE Allen keys
- 1-1/8" Socket and Calibrated Torque Wrench
- Hammer
- Sledge hammer (for installing anchor bolts)
- Rubber mallet
- Phillip screwdrivers
- Flat blade screwdrivers
- Snap ring pliers
- (1) 10 ft. Step ladders
- (1) 4 ft. Level
- (1) rotary hammer drill with 16mm diameter masonry drill bit
- Lifting devices: Use proper lifting devices such as cranes or a forklift.
- (8) 4" x 4" x 2FT wooden blocks (use for unpacking)
- (2) Persons
- Gloves
- Air Compressor

### List of items included in shipment:

- 1 — Power Side Column
- 3 — Non-Power Side Columns
- 2 — Lifting Carriages
- 4 — Ramps
- 2 — Runways
- 1 — Cylinder
- 1 — Long Hydraulic Hose
- 1 — Air Hose
- 1 — Pneumatic Push Button
- 1 — Power Unit
- 2 — Chocks
- 4 — Safety Latch Cover Assemblies
- 1 — Hardware Kit
- 1 — Full Attached Safety Label Kit
- 1 — Installation Manual
- 16 — Expansion Anchor Bolts M16x150
- 1 — Installation Agreement signed by purchaser and submitted to TORIN for Lift Valid Warranty.

***A Qualified person should be consulted to address seismic loads and other local or state requirements.***

***A Qualified and Licensed Electrician should be consulted to install Electric Hydraulic Power Unit.***

***This car lift is designed for indoor installation, prohibiting outdoor installation of this lift.***

***Approved only for indoor installation. Outdoor Installation is not Recommended.***

## Product Layout

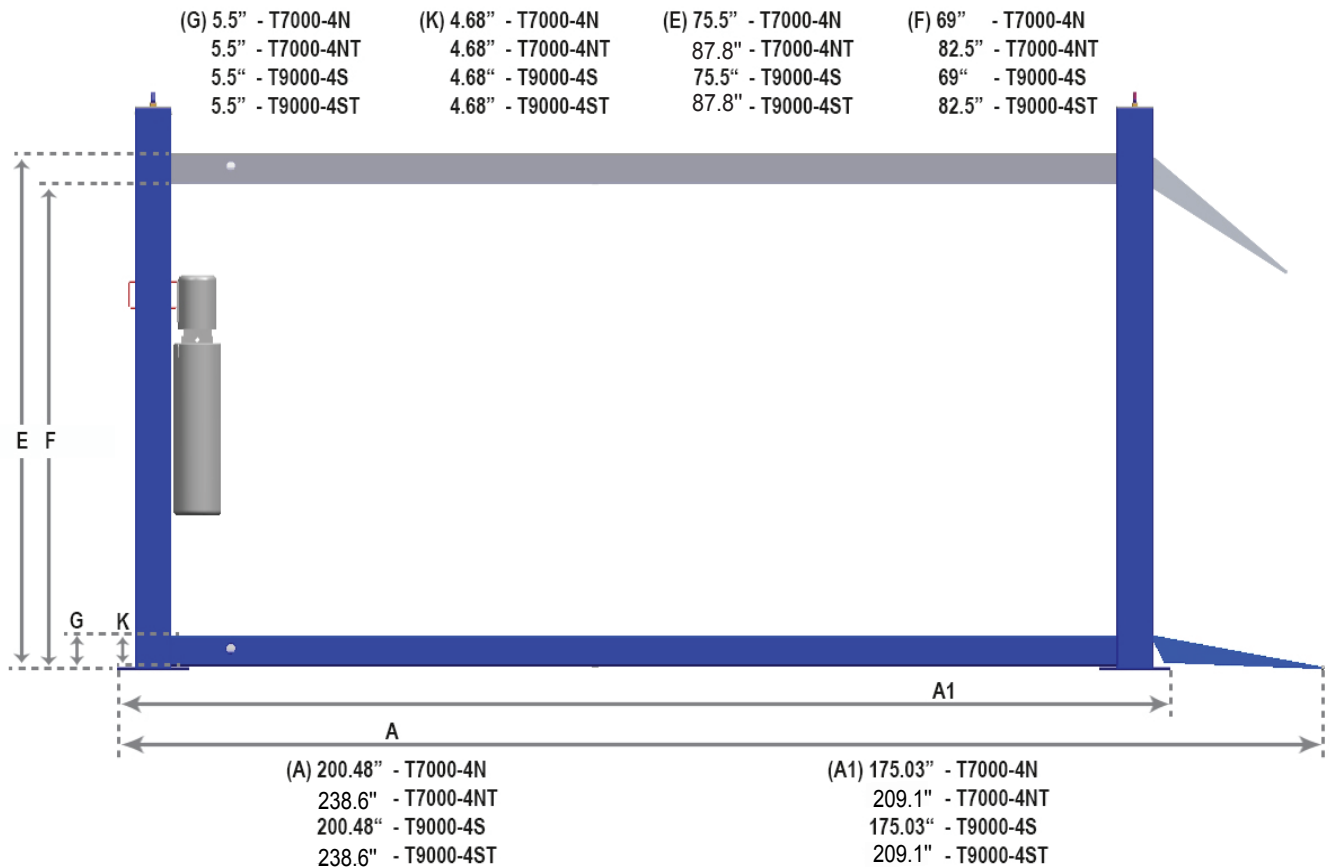
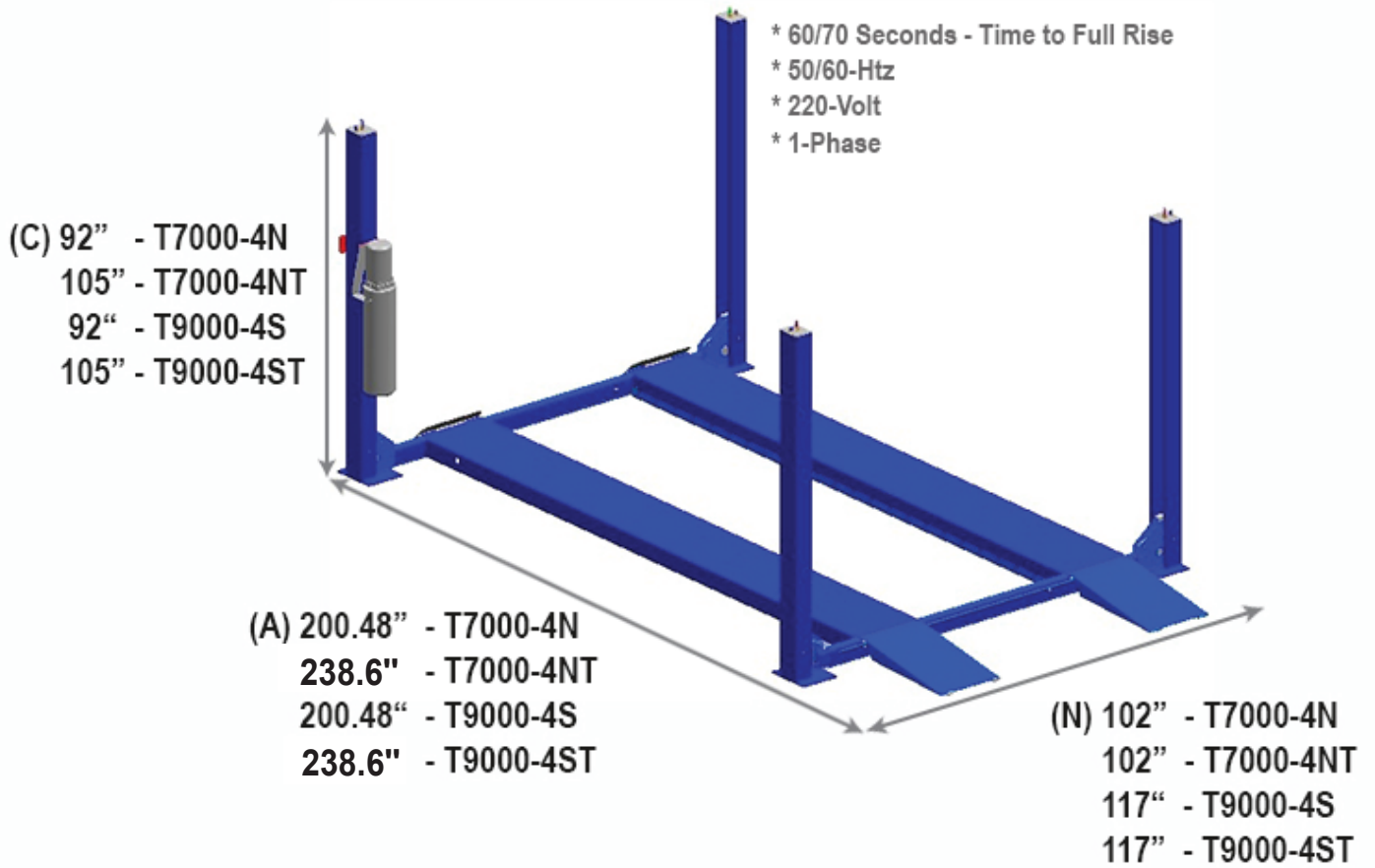

## Product Layout

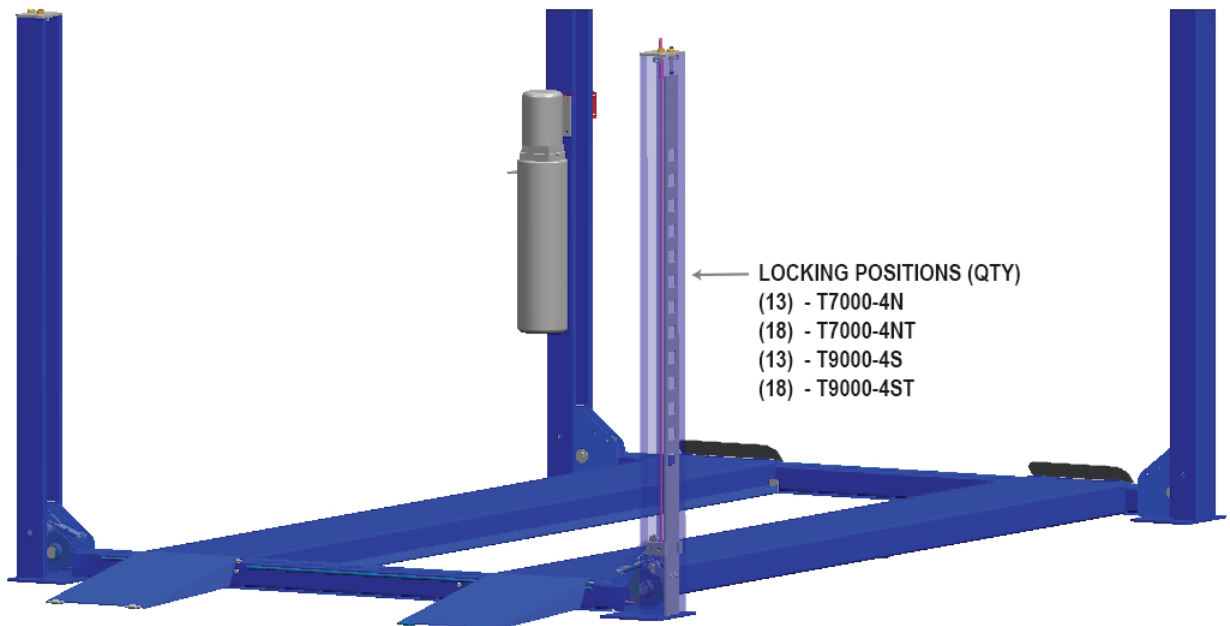
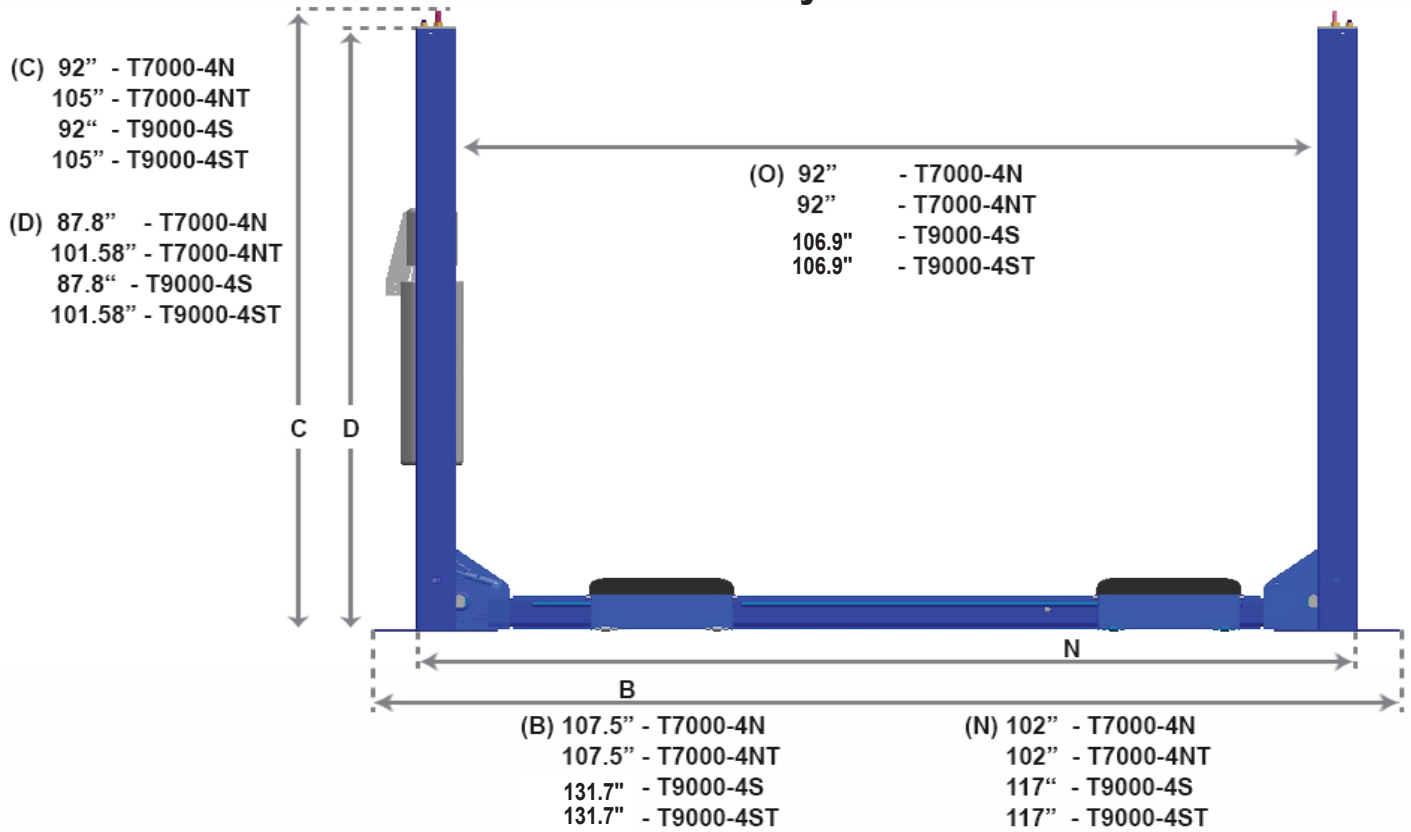

Packaging Illustration

# Product Layout

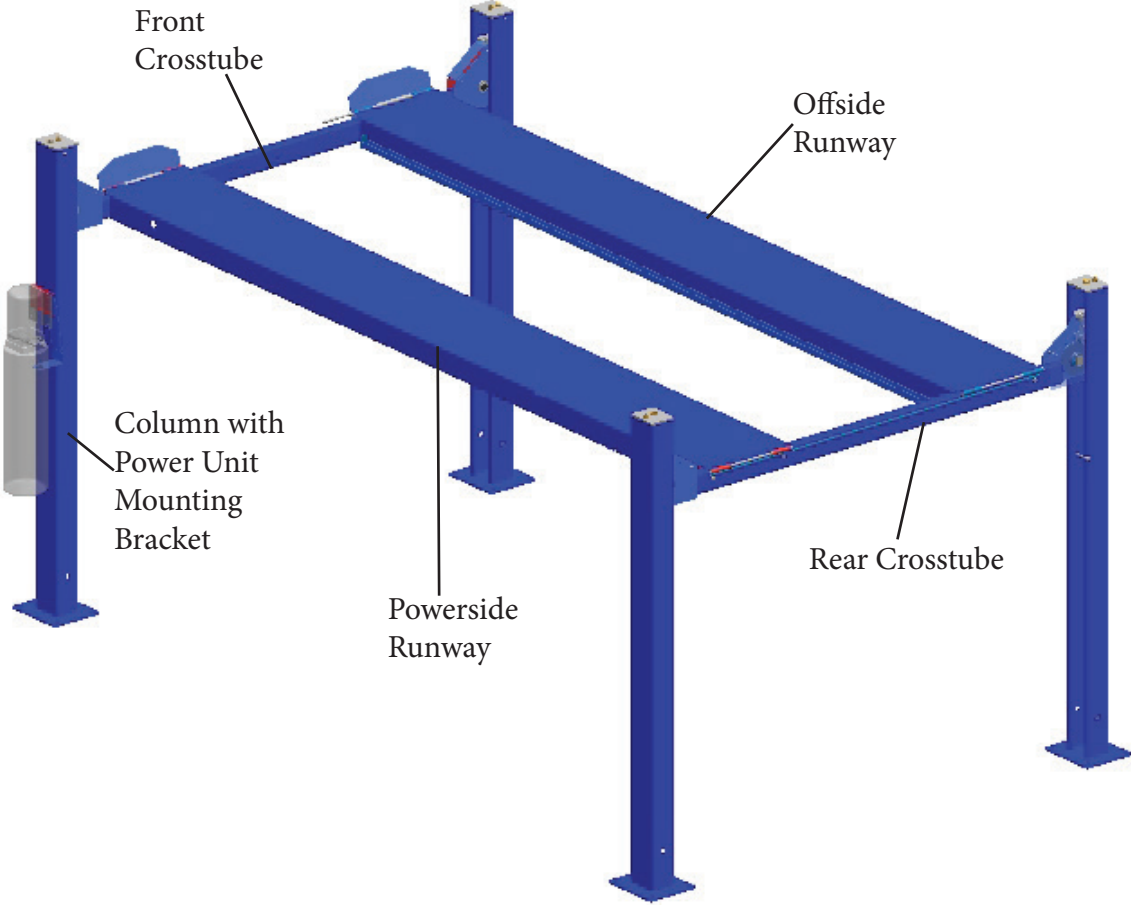
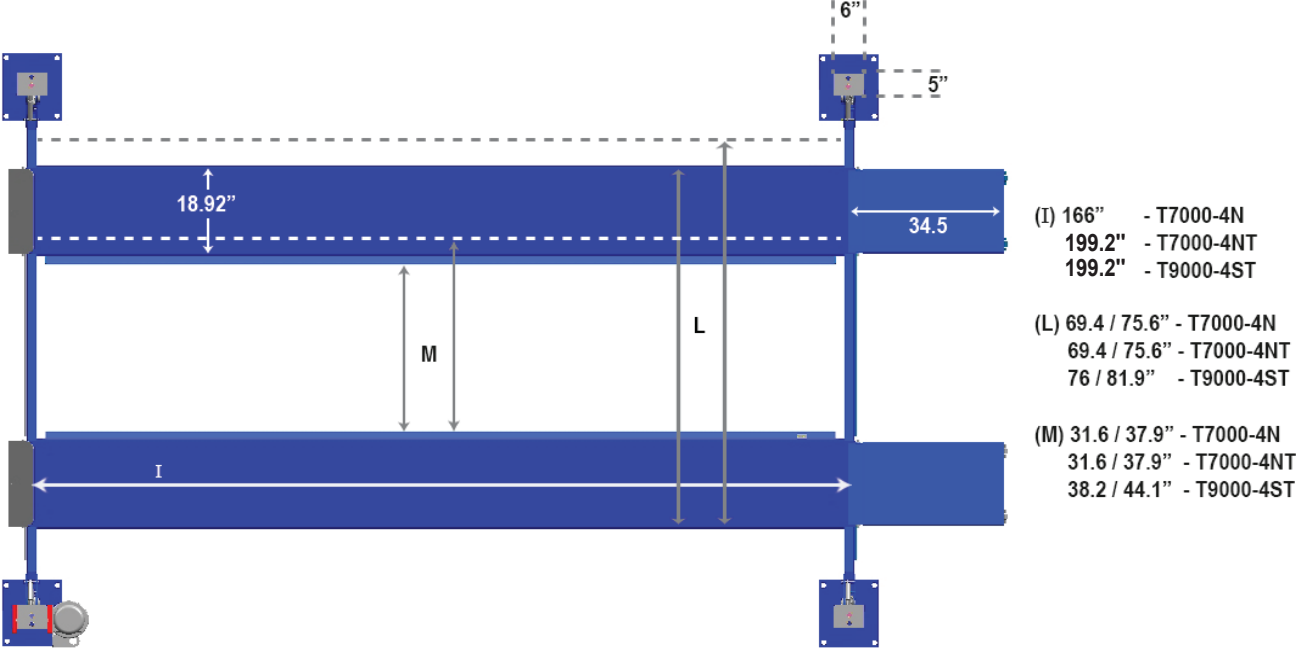

# Product Layout

## Optional Items NOT Included:

- Caster Kit
- Rolling Bridge Jack
- Oil Drain
- Oil Drip Trays
- Air Kit
- Air Tank

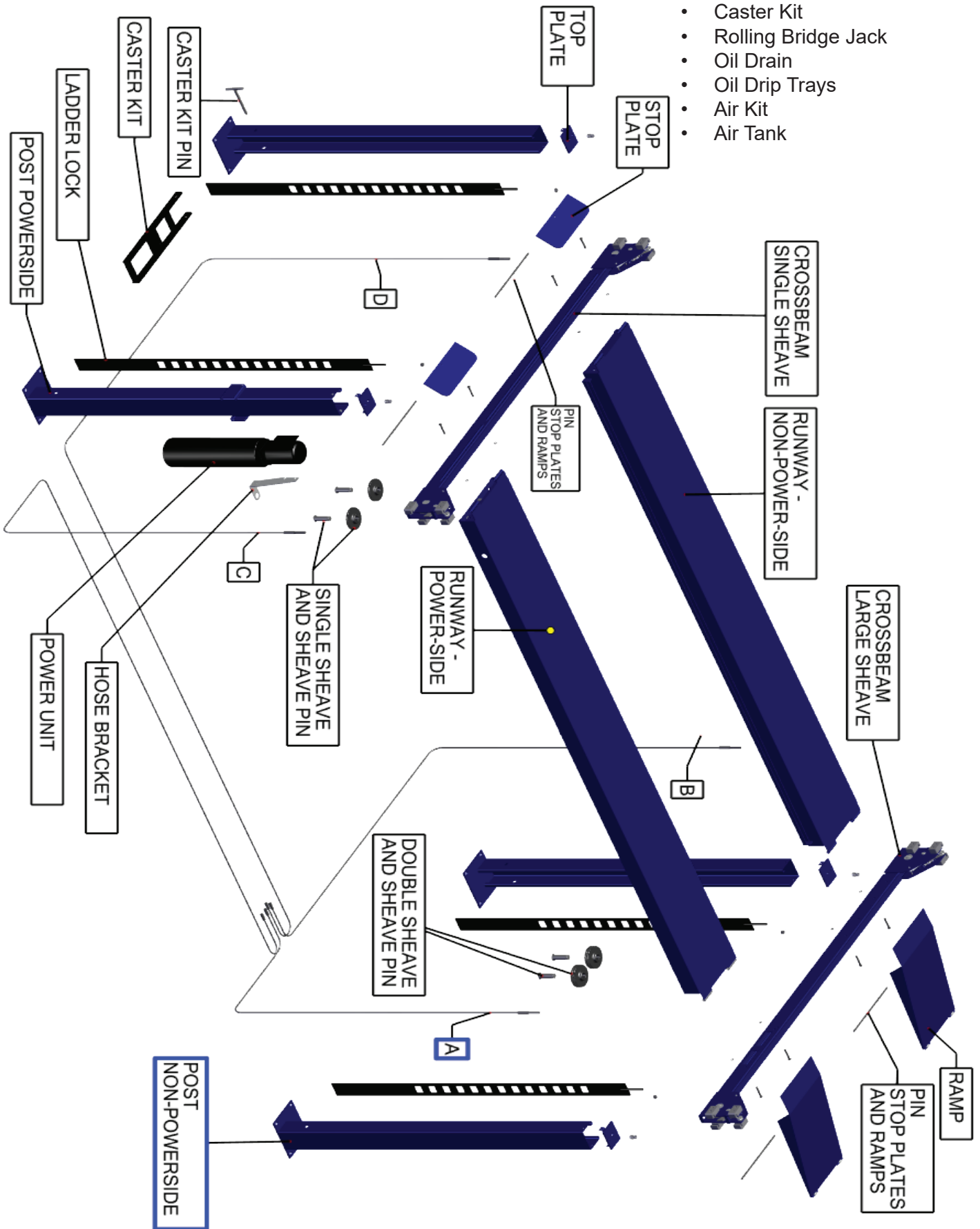

## INSTALLATION PROCEDURE

Use safety protective clothing and protective wear when installing lift.

DO NOT install this lift outdoors unless special consideration has been made to protect the power unit from weather conditions. The Power unit is not waterproof!!!

DO NOT begin installation with lift close to wall. It is necessary to leave adequate clearance for installing safety linkage rods. Allow 1524mm for clearance. (See Fig.1)

NOTE The power unit can be placed in one of two locations, front left or rear right (See Fig. 1)

STEP 1: After unloading the lift, place it near the intended installation location.

STEP 2: Remove the shipping bands and packing materials from the lift. The power unit will be unpacked from the top. Note: Be care-ful not to drop power unit on heavy end

STEP 3: Open the wrapping, remove the parts and parts boxes from the packaging. Unbolt the structure from the shipping brackets. (Use proper lifting devices, cranes or a forklift to lift off of shipping brackets.)

Step 4: Before assembling lift stand the columns in place making sure to position the power unit mounting bracket at the correct location and the lock blocks are positioned facing outward. The power unit column will be positioned with the power unit ramp DANGER When removing the lift from shipping angles pay close attention as the posts can slide and can cause injury .Prior to removing the bolts make sure the posts are held securely by a fork lift or some heavy lifting device.

## POWER UNIT LOCATION

### IMPORTANT NOTE

The Power Unit can be located at either "X" location shown below. It is important to locate the POWERSIDE Runway (with Cylinder) on the SAME SIDE as the power unit location . Utility rails on the side of each Runway MUST be installed to the inside .

For the remainder of this instruction we will illustrate the Power Unit mounted at the DRIVER-SIDE (LEFT) FRONT Column-TOP ILLUSTRATION. For Power Unit at right rear ,rotate lift 180 leaving Approach Ramps and Front Tire Stops in original position .

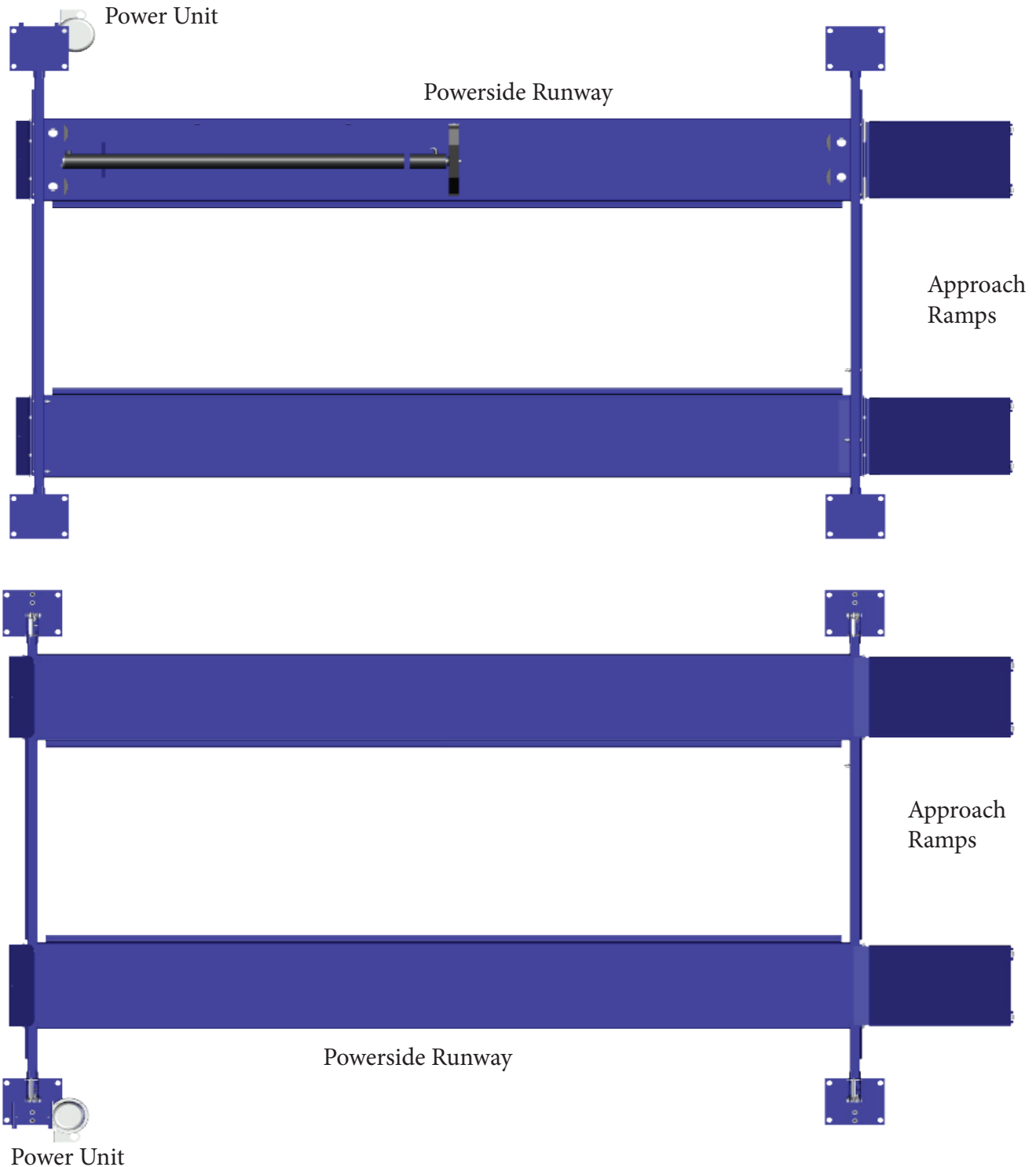

**STEP1**

(Column & Cross Tube Installation)

1. Place components on the floor according to the floor plan layout. Pay attention to the power Unit location, Locate and stand the column at the respective locations, **DO NOT BOLT** Columns down at this time, use caution to prevent the Columns from falling over.

**SHEAVE WINDOWS SHOULD BE FACING DOWN WHEN INSTALLED**

**Side blocks must be in position when installing**

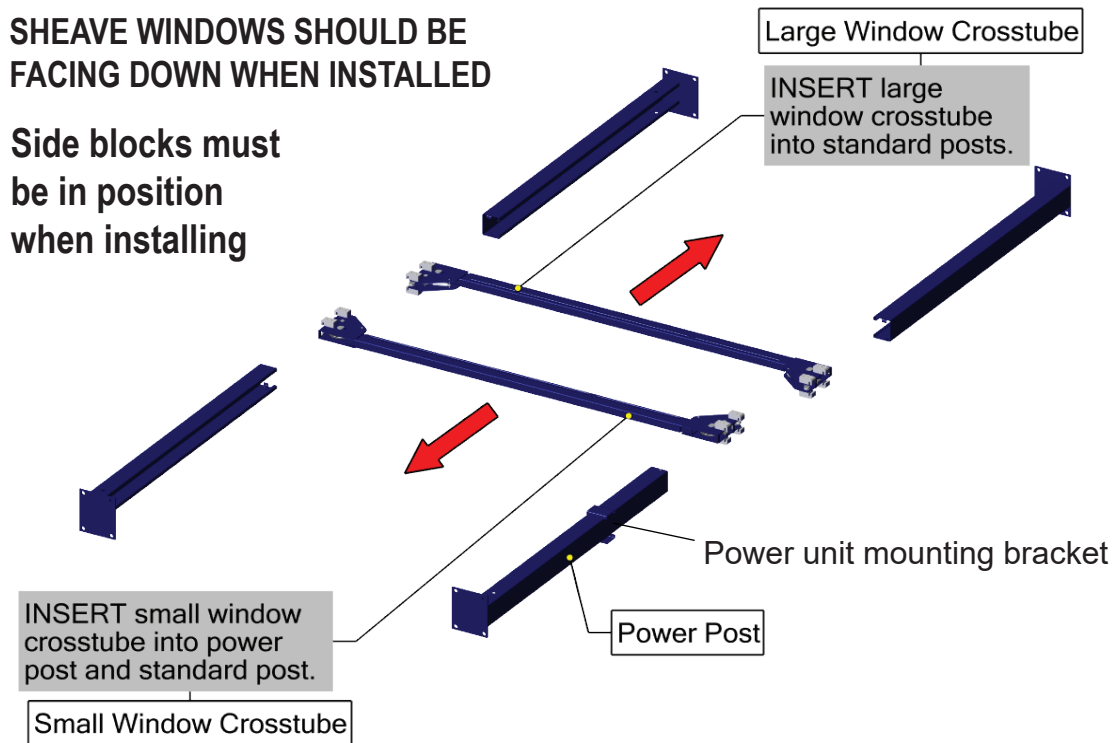

2. Insert the cross tube (making sure that Plastic Side Block are still in position) and slide into the top of the Columns, **NOTE:** The Sheave windows should be positioned inward and adjacent the Power Unit Column.

**IMPORTANT NOTE!**

Lower the cross tubes all the way down and rest on the floor, **DO NOT** install the safety ladders inside the columns until the cross tubes are in position

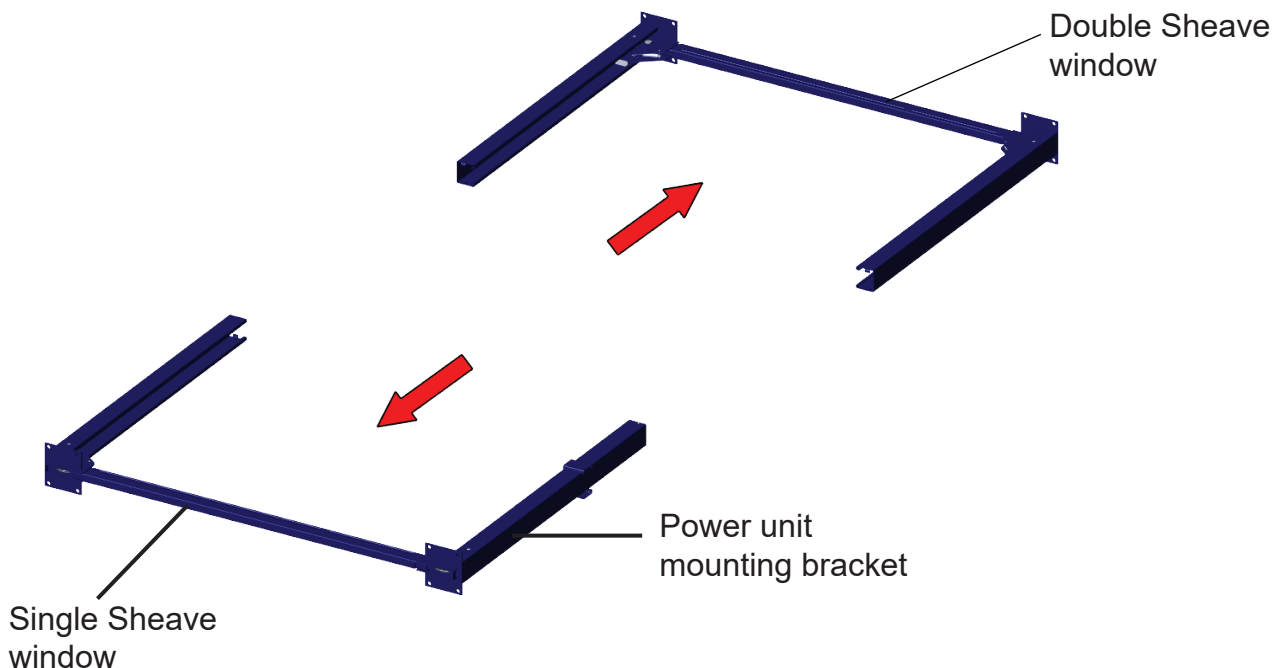

3. With an assistant raise each column and crossbeam as shown. USE CAUTION when raising to not bend or damage posts. RAISE LEVEL WITH ASSISTANT.

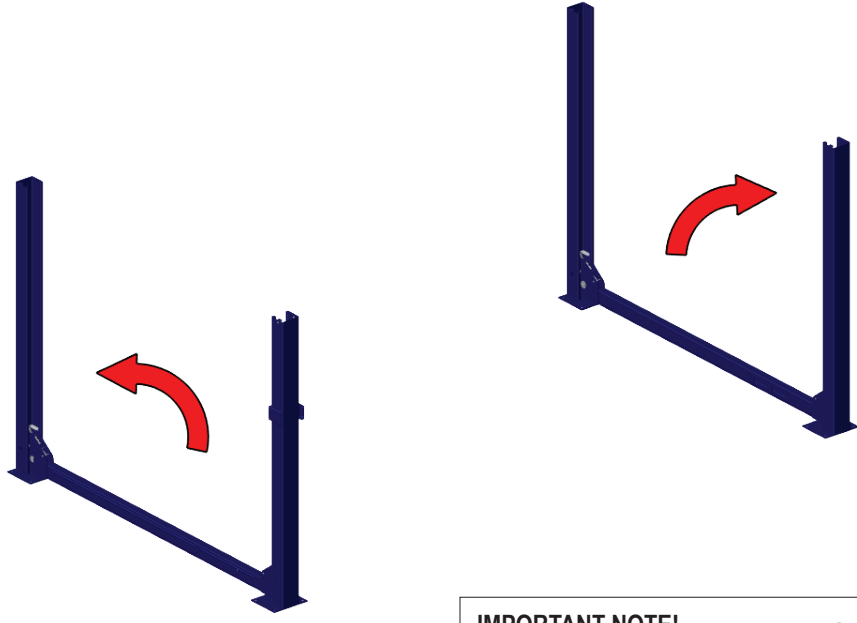

4. With the Columns standing and cross tubes in position, install the Safety Ladders, Pass the Ladders through the Column openings and drop down through the Slide Block guide slots on the Cross Tube until the Ladders come to rest on the Base Plates, if bolting, DO NOT BOLT Columns down at this times. Repeat steps for all four column ladder locks.

**IMPORTANT NOTE!**  
 Position a nut on the thread rod as shown PRIOR to installing the column top caps

This nut will secure the ladder and prevent it from rising upwards while the lift is being operation

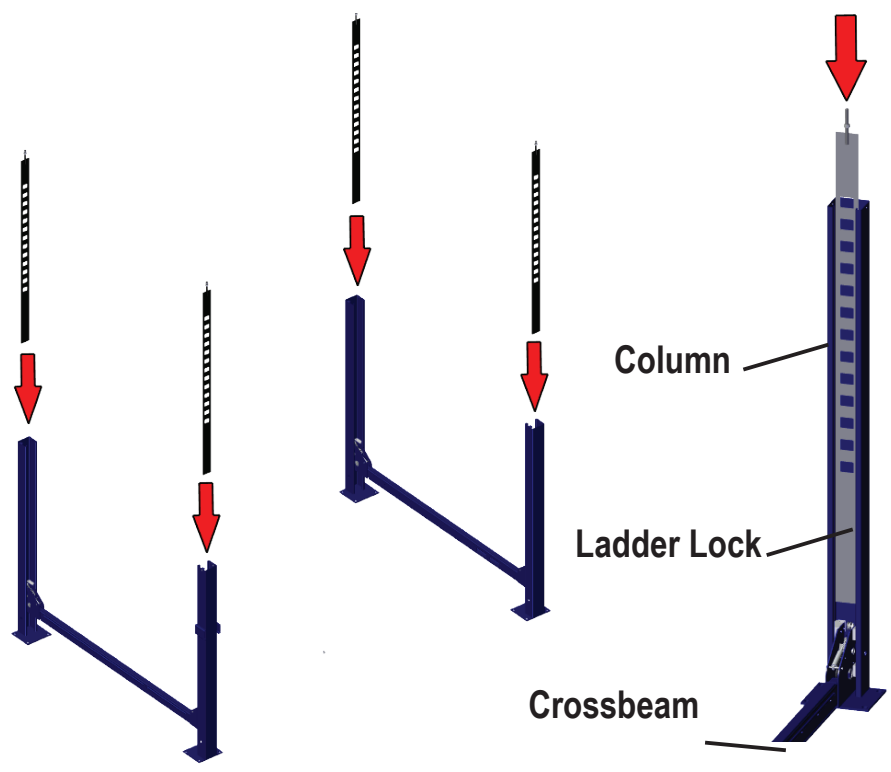

## Safety Ladder Installation

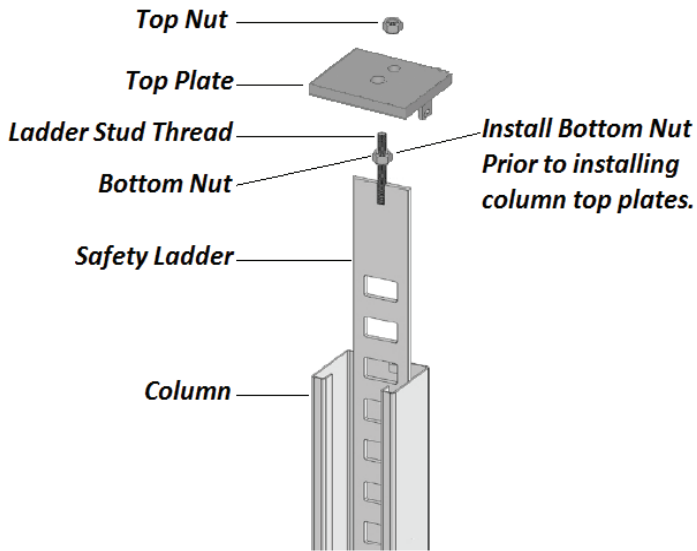

Step 5: Make sure to install bottom nut on safety ladder stud threa before installing top plate. Install top plate and secure top plate with the (4) mounting bolts, nut and washers.

6. Install the Column TOP PLATES using the M8x20mm HEX bolts, nuts & washers. Install the nut on each Safety Ladder until 1/2" of threads are exposed and the Ladder is raised at least 1/2" off of the base of the Column.

NOTE: Raise the Ladder at least 1/2" off of the base of the Column or damaged to the lift will occur. Be sure to position the cable hole INWARD.

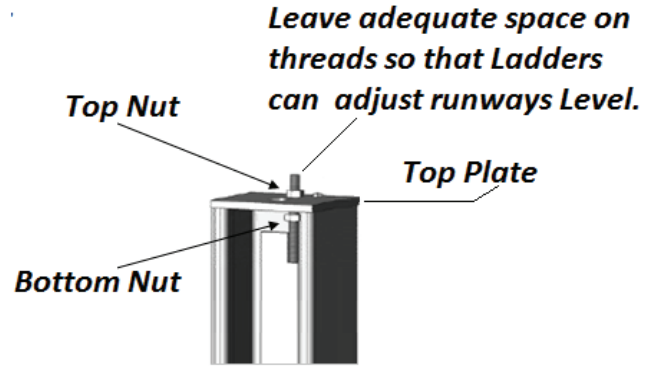
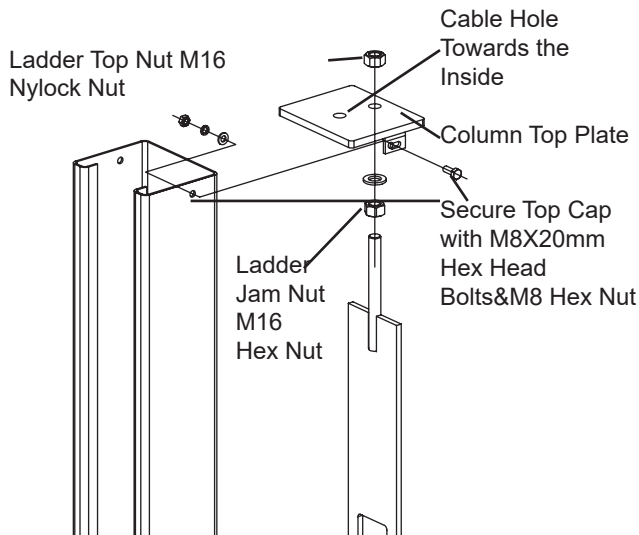

### **Important Note:**

**The top and bottom nuts will secure the safety ladder and prevent it from raising upward when in operation.**

### **WARNING**

DO NOT raise the ladder more than one inch off of the base of the column or damage to the lift will result.

Tighten the top nut on each safety ladder until one inch of threads are exposed and the ladder is raised at least 1/2" off of the base of the column.

Install the M16 nylock nuts and M16 washer on each safety ladder above the top plate until approximately one inch of threads are exposed.

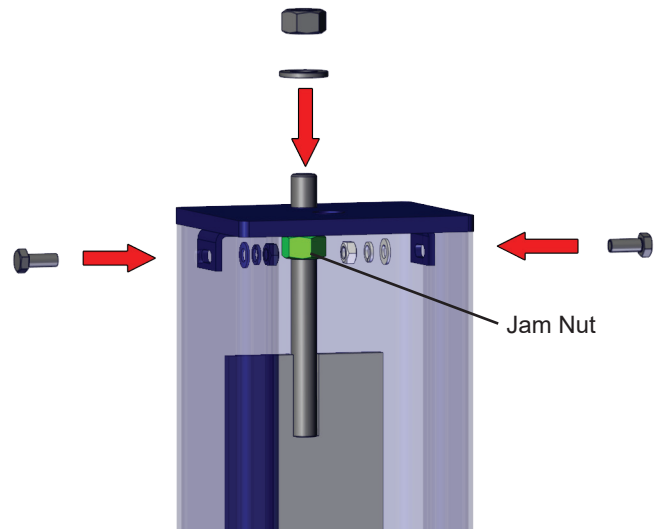

## STEP 2 (Raising The CROSSBEAMS)

1. Before proceeding it will be necessary to first raise the Cross Tubes off the ground to facilitate Cable routing and final assembly.

### DANGER

#### DANGER

Be careful not to disturb the Columns and Cross tubes as they may tip over causing personal injury or harm.

#### IMPORTANT NOTE!

It is important that the SLACK SAFETY LOCK IS CLEARED. The Slack Safety Lock must never rest on the Safety Ladder.

2. Manually raise the Cross Tubes until the primary Safety Locks engage and rest on the Lock position 6th from the bottom of the Ladder or comfortably off the ground. It is important that the SECONDARY SAFETY LOCK IS CLEARED. The SECONDARY Safety Lock must never rest on the Safety Ladder.

#### Dual Safety Locking Mechanism

Primary Safety

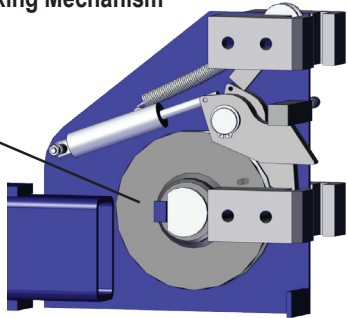

Secondary Safety should be positioned as shown.

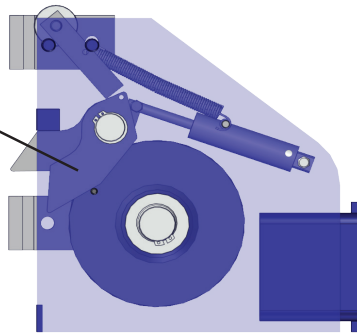

Primary Safety

Secondary Safety

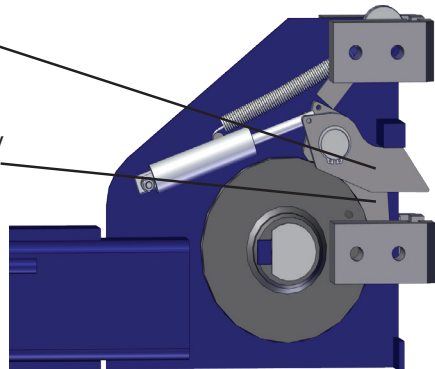

3. The Columns and Cross Tubes will now be in position and spaced properly for the Runways. Be very careful not to disturb the Columns and Cross Tubes at this time as they may tip over causing personal injury or harm.

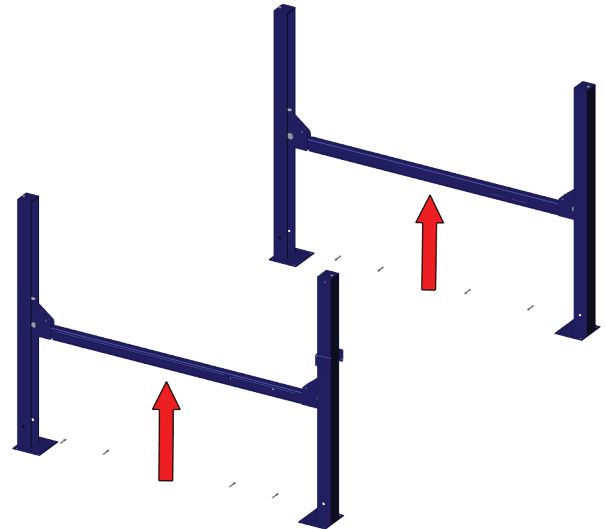

5. The columns and Cross Tubes will now be in position and spaced properly for the Runways.

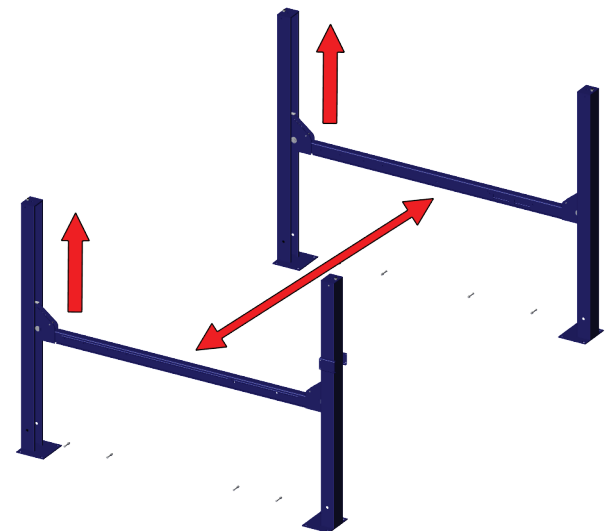

## Runway Installation

Start with the runway with the cylinder. This runway will be located with the hose connection facing out toward the column with the power unit bracket attached.

Note: The power unit can be located as shown.

With a crane, lifting device or forklift pick up and place one end of the power-side runway on the crossbeam, and then pick up and place the other end of the opposite crossbeam (with your assistants, lift at the same time).

Use a large screwdriver or aligning punch to align the mounting moles in the cross rails with the mounting holes in the track. **Do no leave the runway unbolted, INSTALL THE MOUNTING BOLTS IMMEDIATELY.**

Install M12x100mm mounting and M12 washers thru the ramp brackets and wheel stops. Make sure the bolt head is on the flat side of the bracket.

Install the offside track and again secure with ramp bracket, wheel stops with M12x100mm bolts and nuts.

After both tracks are installed, tighten all bolts M12x100 and torque to specified torque rating 78-lbs.

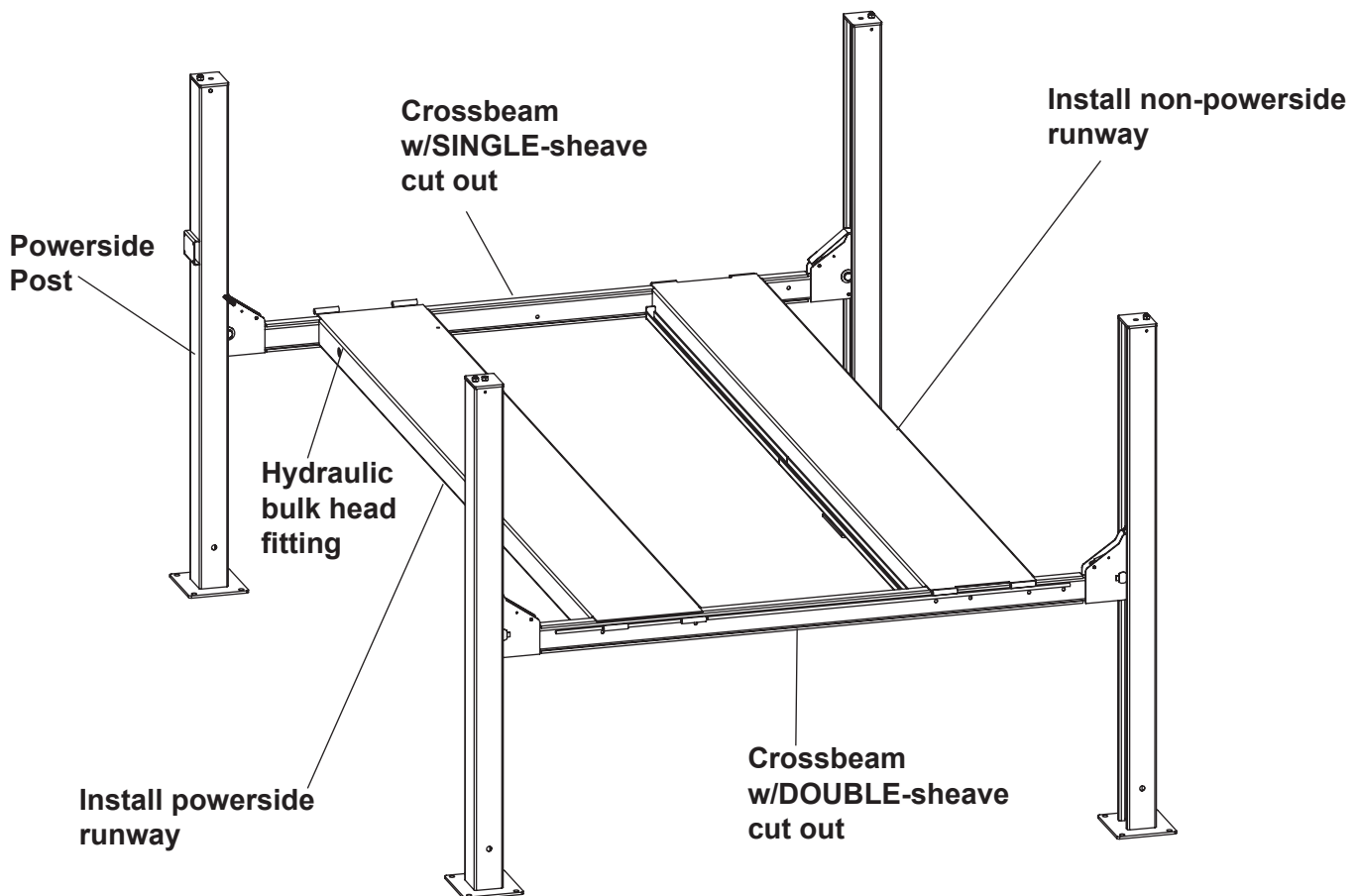

**STEP 3**  
(Powerside Runway Installation)

1. Locate the Powerside Runway easily identified by the Cylinder and Sheave roller mounting structures welded on the underside. The Powerside Runway will be positioned on the side of the lift where the power units is installed.

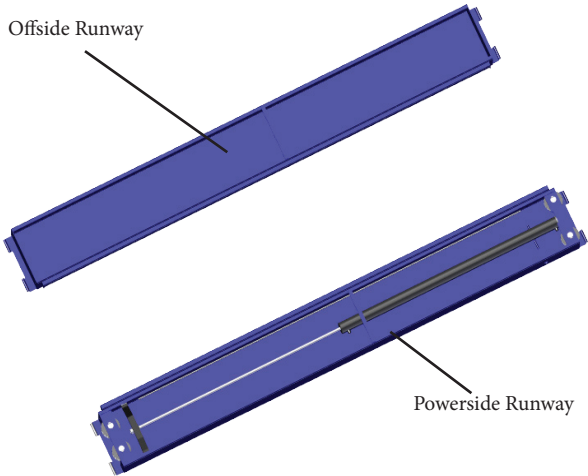

3. Remove any pre-installed Cable sheaves from the Powerside Runway making sure to pay attention to the order in which they are removed (This will help at the time of re-installation)

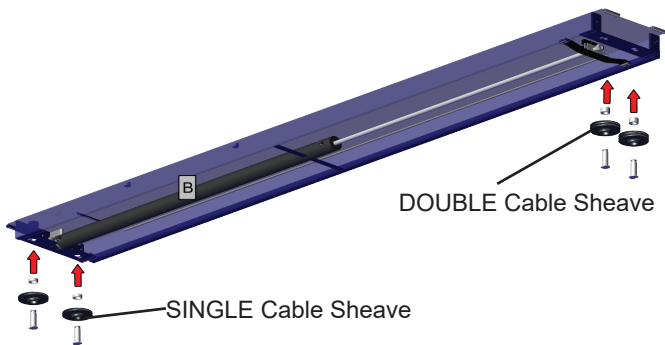

4. Position the powerside Runway on top of the cross Tube with the utility rail towards the center. The Flex Tube Holes located at the side of the powerside Runway should be adjacent to power unit column, Align the holes in the runway with the holes on the Cross Tube and bolts together using four M12x100mm Hex Head Bolts and Washers, Lubricate bolts with WD-40 or equivalent and torque to rate ft/lbs.

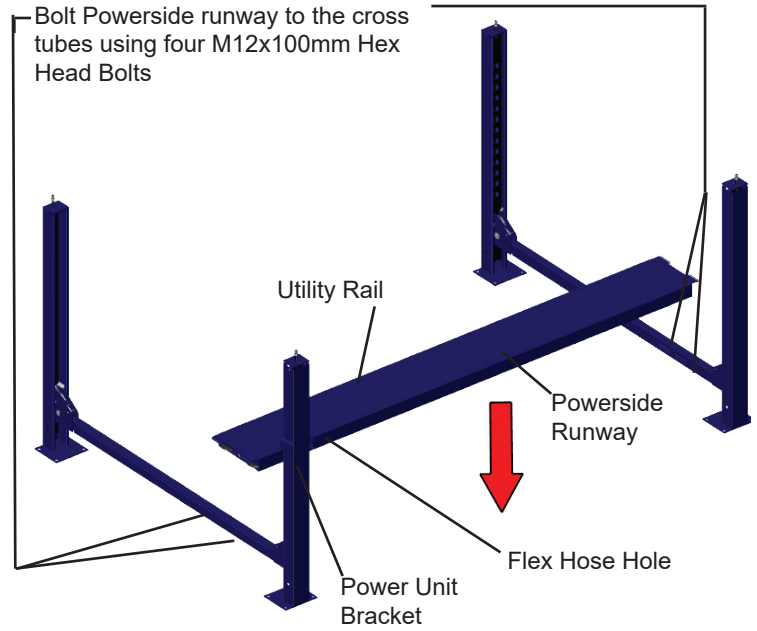

**STEP 4**  
(Offside Runway Installation)

Position the Offside Runway on top of the Cross Tubes with the Utility Rail located inside, Determine the desired location of the Offside Runway. align the holes in the Runway with the desired holes on the cross tubes and bolt together using four M12x100mm Hex Head Bolts and Washers, Lubricate bolts with WD-40 or equivalent and torque to rated ft/lbs.

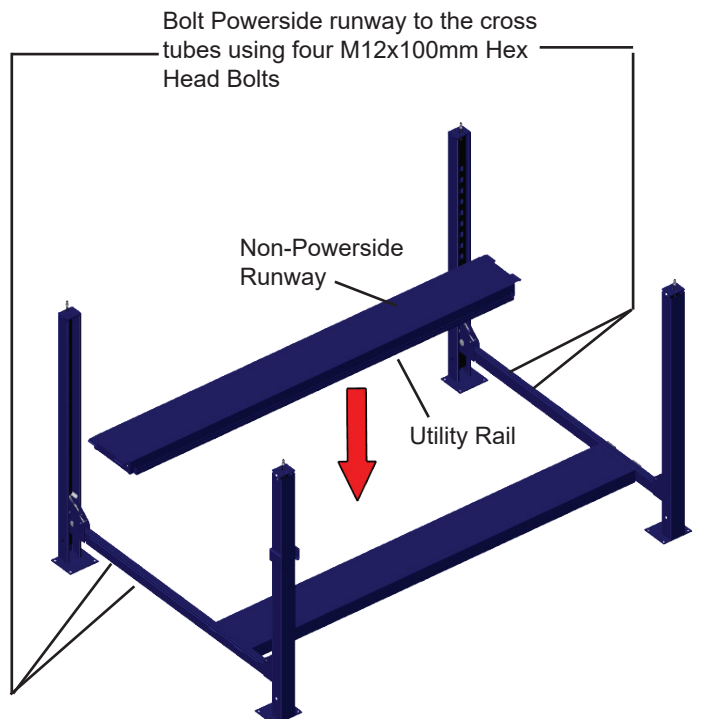

**STEP 5**  
(Cable / Sheave Installation)

1. Inspect Cables to insure proper lengths , All Cables should have ID tags showing proper Cable lengths.
2. In order to install the Cables it is necessary to first extend the hydraulic Cylinder. Remove both Cylinder port plugs then use an air gun or come-along to extend the Cylinder.

**IMPORTANT!-Be careful not to damage the chrome rod during this step.**

**WARNING**  
DO NOT exceed 50 PSI. if cylinder does not move . STOP and use a come-along or other Pulling devise. Keep hands clear.

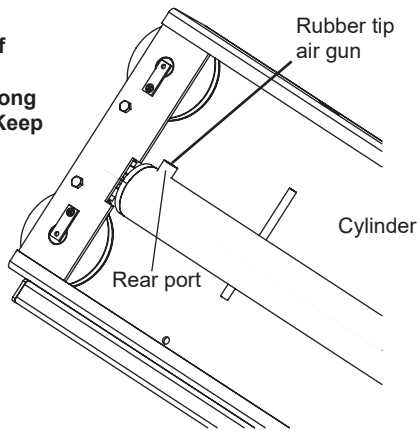

3. You must reinstall the Sheaves. Spacers and Pins in the same order as they are removed.

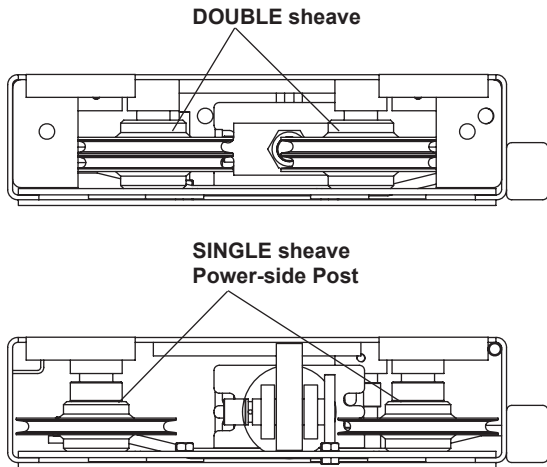

**DANGER**

**DANGER**  
DO NOT PRECEED with cable installation or go new the lift work area unless visual confirmation is made of ALL Safety locks. ALL locks MUST be engaged before proceeding. Failure to comply with this instruction may result in severe personal injury or death

**DANGER**

**DANGER**

Failure to route lifting Cables as described may lead to serious personal injury and/or death to operator or bystander and/or may cause damage to property.

**STEP 6**  
(Cable Installation)

1. Make sure the Cylinder Flange Plate is installed with the guide assembly facing down and the Cylinder Retaine' plate on the outside of the guide. Lug ends of Cables start at Cylinder.

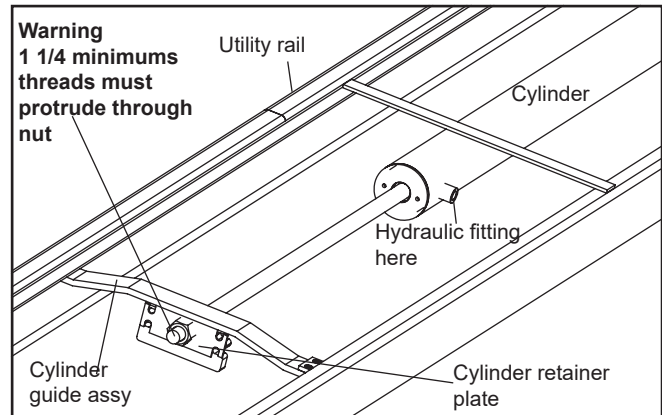

2. Route the threaded Cable ends through the ends of each Cross Tube. Care must be taken when routing the Lifting Cables to ensure they are routed below the Cross Tube Mounting Bolts.

**DANGER**

Care must be taken when routing Lifting Cables through the Cross Tube. Lifting Cables must be run BELOW Cross Tube Mounting Bolts. Serious damages or injury may occur if Cables are not routed properly.

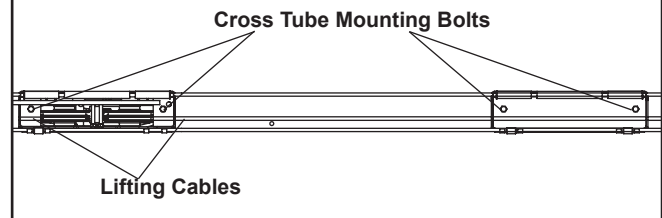

3. Route Cables over the Secondary Safety Sheaves then to the top of each Column. Secure using the M18 Hex Head Nuts and Flat Washers. (See NEXT 2 PAGES)

# CABLE ROUTING

All cables **MUST** remain in sheave grooves. Before start-up, check all cables for proper routing.

**DANGER:**  
DO NOT ATTEMPT TO RAISE LIFT UNTIL ALL CABLES HAVE BEEN VERIFIED THROUGH PROPER ROUTING.

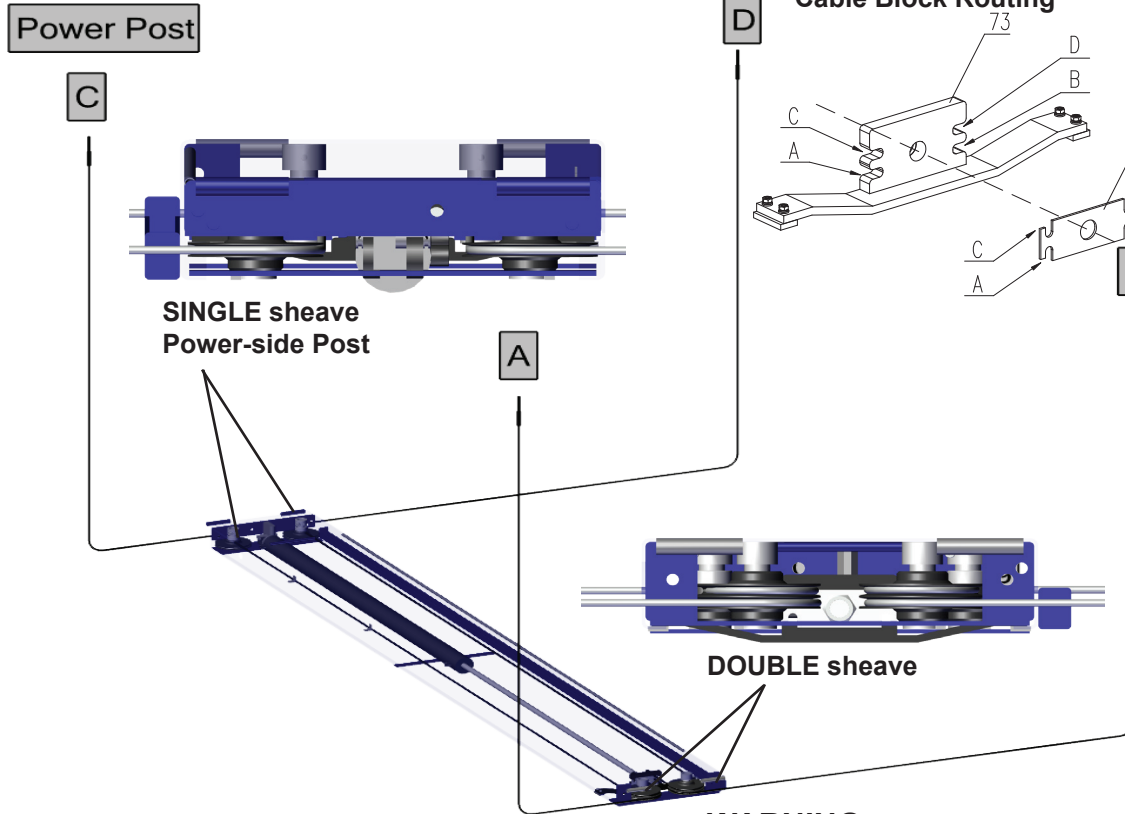
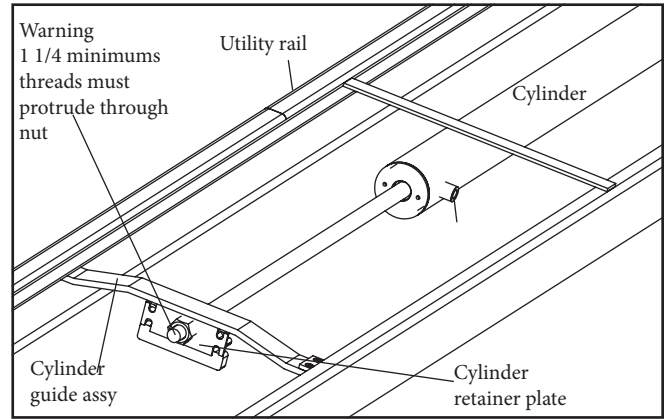

**WARNING:**

All cables **MUST** remain in sheave grooves. Before start-up, check all cables for proper routing.

**WARNING:**

Route lifting cable on **SECONDARY SAFETY PULLEY** as shown  
Attach secondary safety spring here only to allow safety to move freely

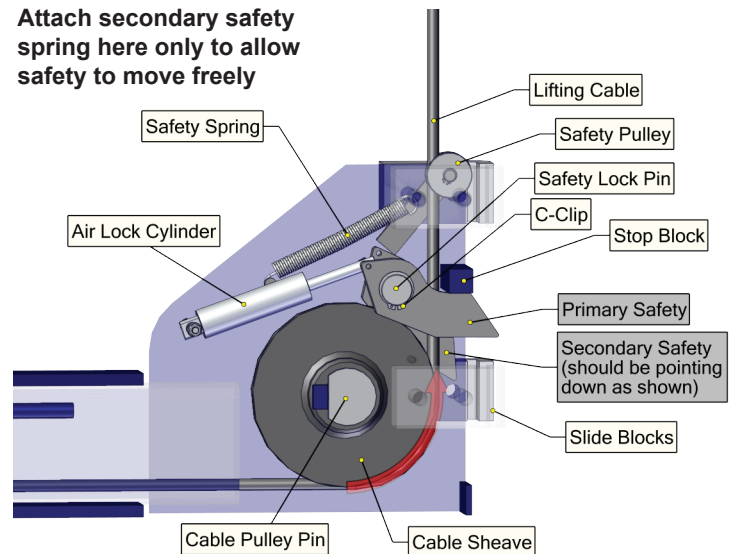
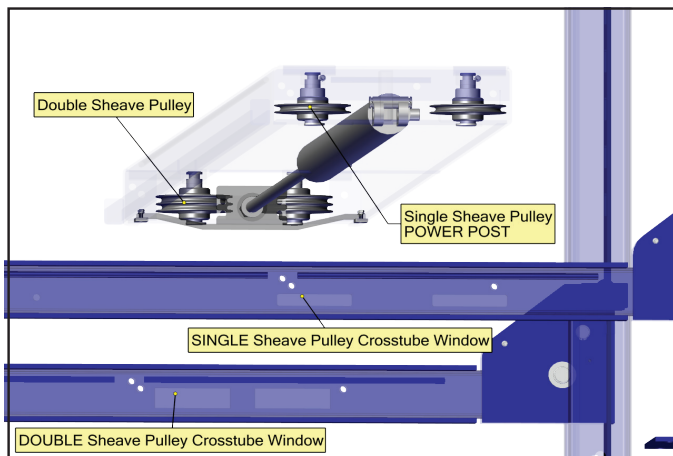

## CABLE ROUTING

### IMPORTANT

It will be necessary to remove sheeves, pins, and spacers prior to cable installation.

You must re-install the components back in the same order as they are removed.

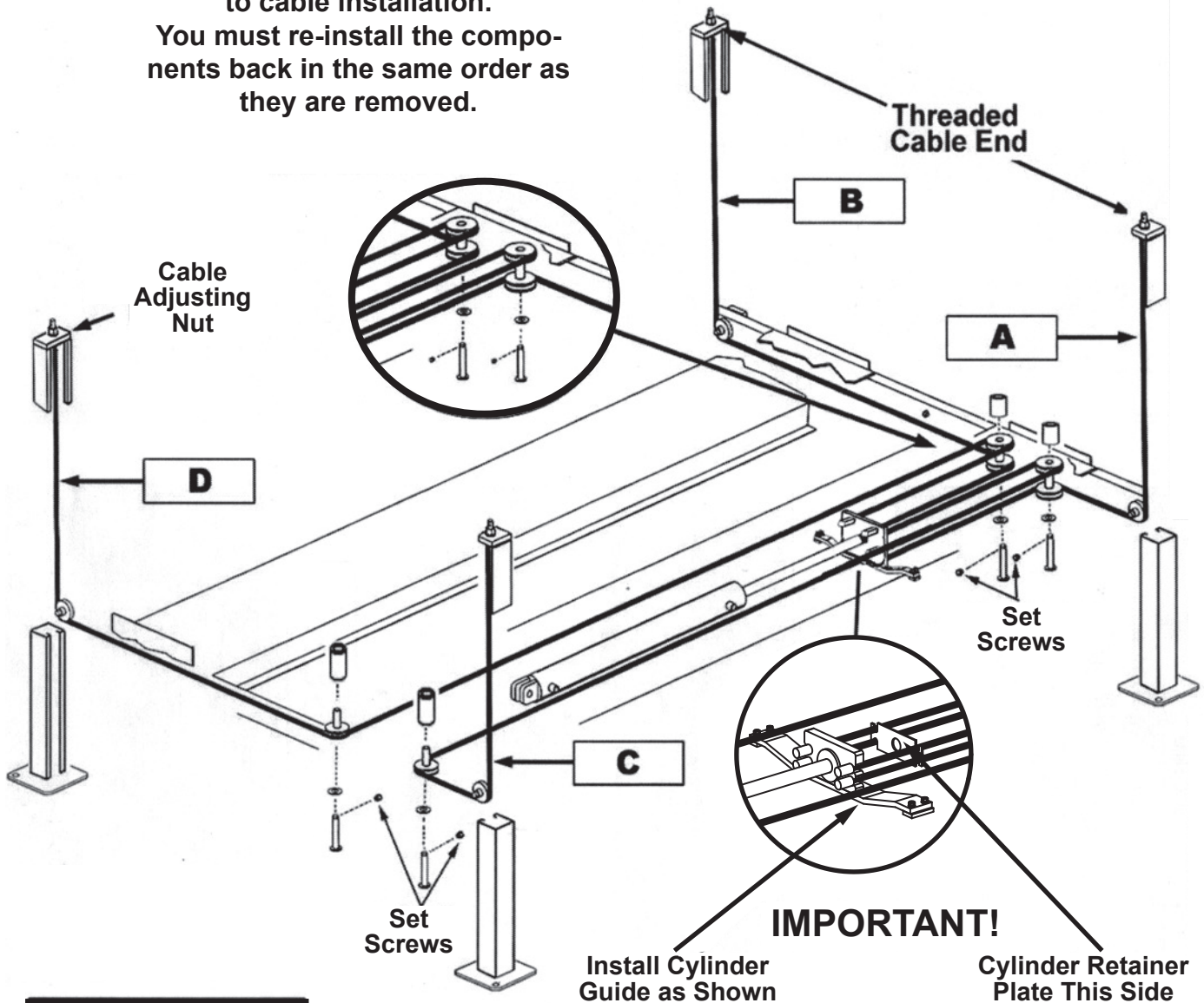

### IMPORTANT!

Install Cylinder Guide as Shown

Cylinder Retainer Plate This Side

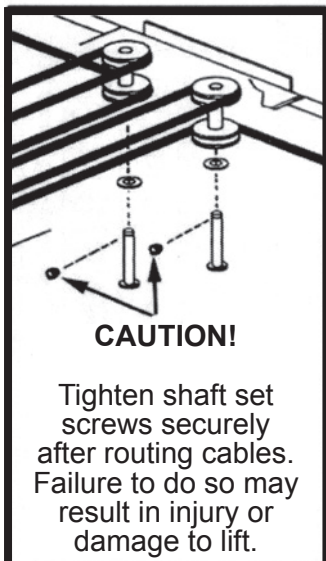

**CAUTION!**  
Tighten shaft set screws securely after routing cables. Failure to do so may result in injury or damage to lift.

4. Tighten each Nut until there is at least one inch of threads protruding through the top of the nut. The cables will remain loose until start up and final cable adjustments are made.

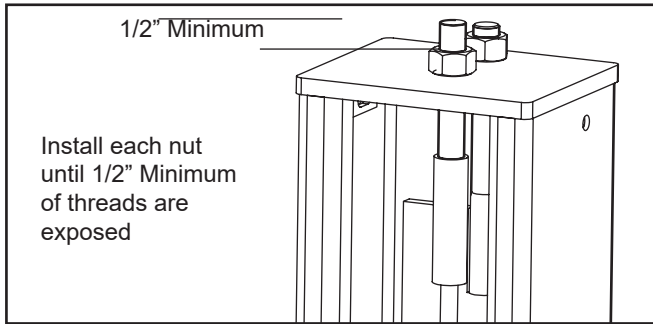

5. After routing the cables double-check to make sure all are properly positioned and remain within the grooves of all sheaves.

### STEP 14

(Attaching the Approach Ramp/Tire Stops)

1. Install the Front Tire Stops at the forward side of the lift using the 18" steel rods and cotter pins.

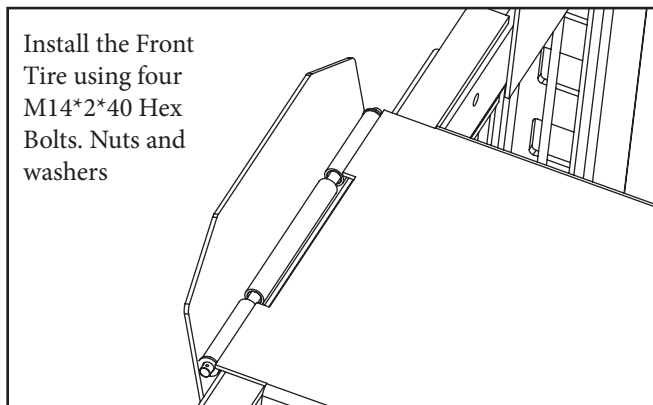

2. Install the Approach Ramps on the entry side of the lift (install the 4 Optional Drive Up Ramp Locks, if desired to keep the drive Up Ramps from Flipping down)

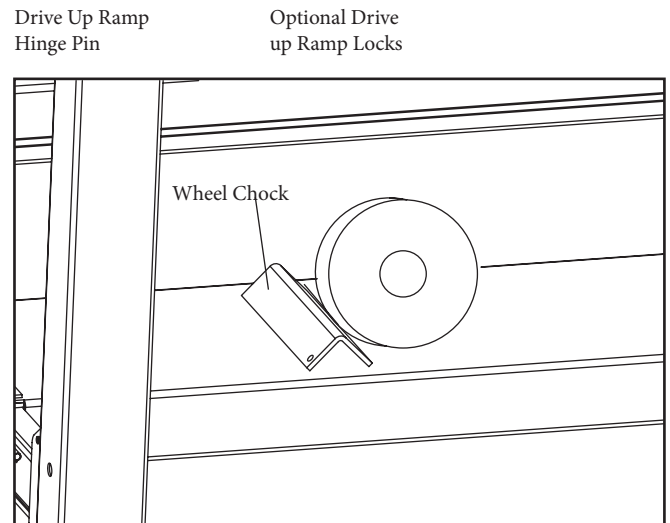

**STEP 7**  
(Power Unit Installation)

1. Mount the Power Unit to the Mounting Bracket using the M8 Hex Head Bolts and Nylock Nuts then fill the reservoir with 12 quarts of 10-WT hydraulic oil.

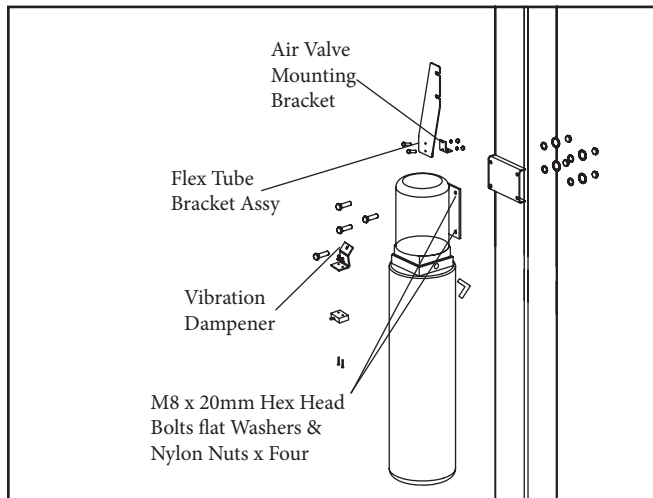

**DANGER**

**ALL WARNING MUST BE PERFORMED BY A LICENSED ELECTRICIAN**

**DANGER**



**DO NOT PERFORM ANY MAINTENANCE OR INSTALLATION OF ANY COMPONENTS WITHOUT FIRST ENSURING THAT ELECTRICAL POWER HAS BEEN DISCONNECTED AT THE SOURCE OR PANEL AND CANNOT BE RE-ENERGIZED UNTIL ALL MAINTENANCE AND/OR INSTALLATION PROCEDURES ARE COMPLETED.**

The standard Power Unit for your lifts is 110 volt, 60HZ, single phase. All wiring must be performed by a certified electrician only. SEE WIRING INSTRUCTIONS AFFIXED TO MOTOR FOR PROPER WIRING INSTRUCTIONS.

**WARNING!**

DO NOT run Power Unit with no oil. Damage to pump can occur.

The Power Unit must be kept dry. Damage to Power Unit caused by water or other liquids such as detergents, acid etc... is not covered under warranty.

Operate lift only between temperatures of 41°-104°F.

Improper electrical hook-up can damage motor and will not be covered under warranty.

Motor can not run on 50HZ without a physical change in motor.

Use a separate breaker for each Power Unit.

**STEP 8**  
(Routing Hydraulic Hoses)

1. Install the 90-degree Hydraulic Fitting to the POWER PORT and the 90° return air Line Fitting to the RETURN PORT of the POWER UNIT and connect the House as described below. It will be necessary to remove the shipping plugs from both ports prior to installing the Fittings.

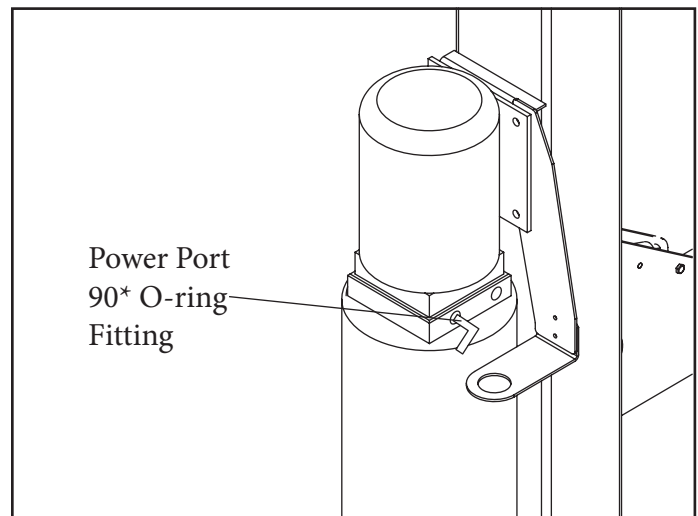

**NOTE:**  
Check the Power Unit to determine proper connection ports for Power and Return lines. It will be necessary to remove shipping plugs from both ports prior to installing Fittings.

2. Install the 90-degree Hydraulic Fitting in the port at the ram end of the Cylinder. On the pipe thread side of the Fitting it is recommended to use Teflon Tape or pipe sealer. DO NOT USE TEFLON TAPE on the JIS flared end.

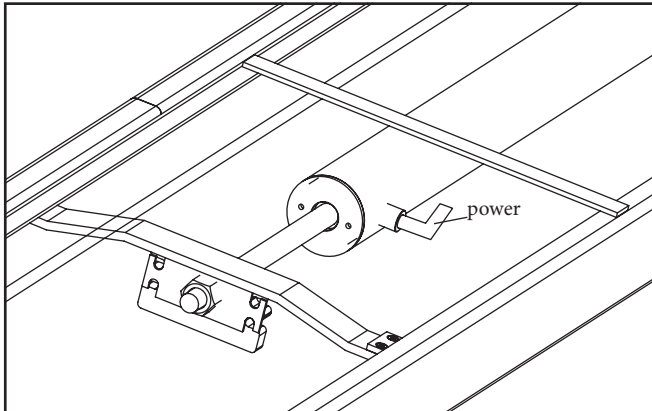

3. Install the 90-degree Air Line Fitting in the port at the base end of the Cylinder. On the pipe thread side of the Fitting it is recommended to use Teflon Tape or pipe sealer.

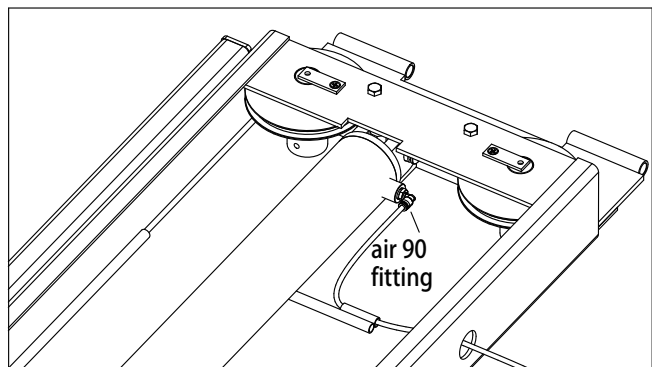

4. Install one end of Flex Hose to into hole in the POWERSIDE RUNWAY adjacent to the power unit. Install the other end of the Flex Hose to the Flex Hose Bracket Assembly. Tighten the Plastic Nut securely.

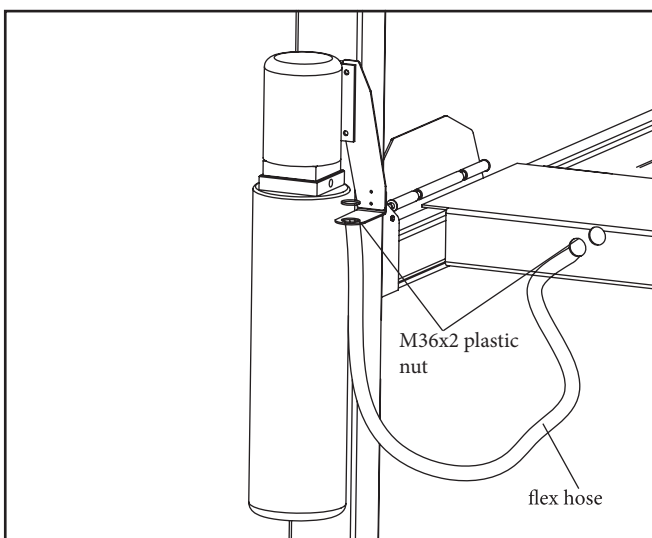

5. Connect Hoses as shown below making sure to pass through the retaining rings. MAKE SURE HOSES ARE KEPT CLEAR OF CABLES.

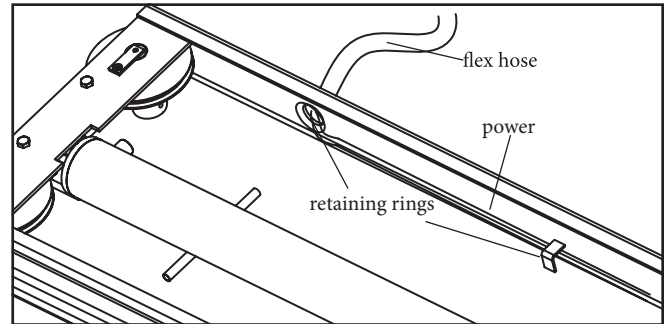

6. Run the Power Unit Hydraulic Hose. (90 degree End towards HPU) and the Return Air Line through the Flex Hose to the Power Unit.

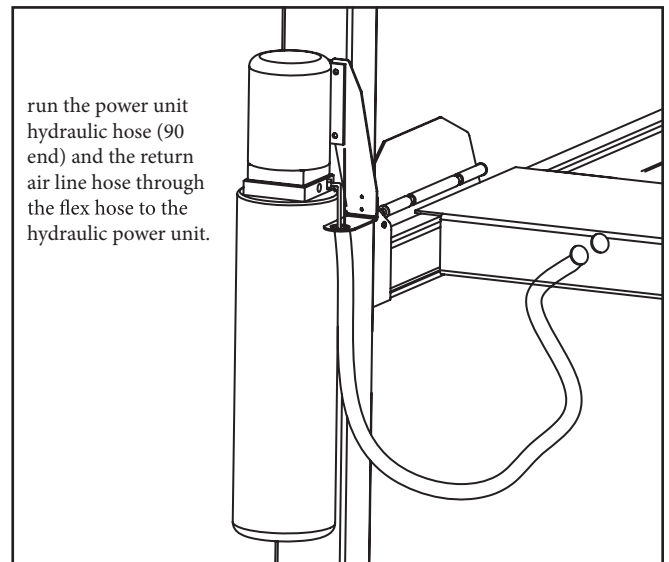

7. Connect the Power Unit Hydraulic Line to the 90 degree Power Unit Fitting. Connect the Return Air Line Hose to the 90 degree Return fitting.

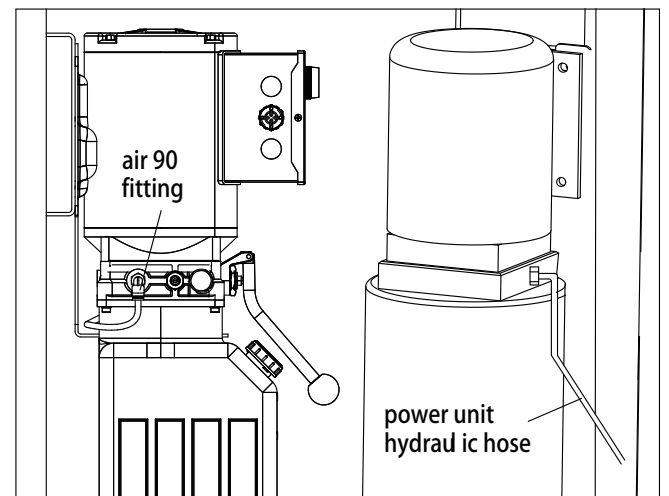

STEP 9  
(Routing Air Lines)

Route the air line as shown below making sure to position the push button air valve with the INLET facing towards the AIR SOURCE and the OUTLET facing the direction of the LIFT.

A filter/regulator/lubricator must be installed on air supply at lift. Failure to do so will void the warranty. Cut the Provided 1/4" air line tubing with a sharp blade to lengths as required. Tubing must be cut square with no burrs.

Note: To assemble air line tubing into fitting, use firm, manual pressure to push tubing into the fitting until it bottoms out.

To remove air line tubing from the fitting, hold push sleeve in (against fitting) and, at the same time, pull out on tubing.

Pay careful attention to keep air line clear of any pinch points. Improper assembly may result in safety lock failure.

**AIR PRESSURE SHOULD BE REGULATED TO 120 PSI MAX.**

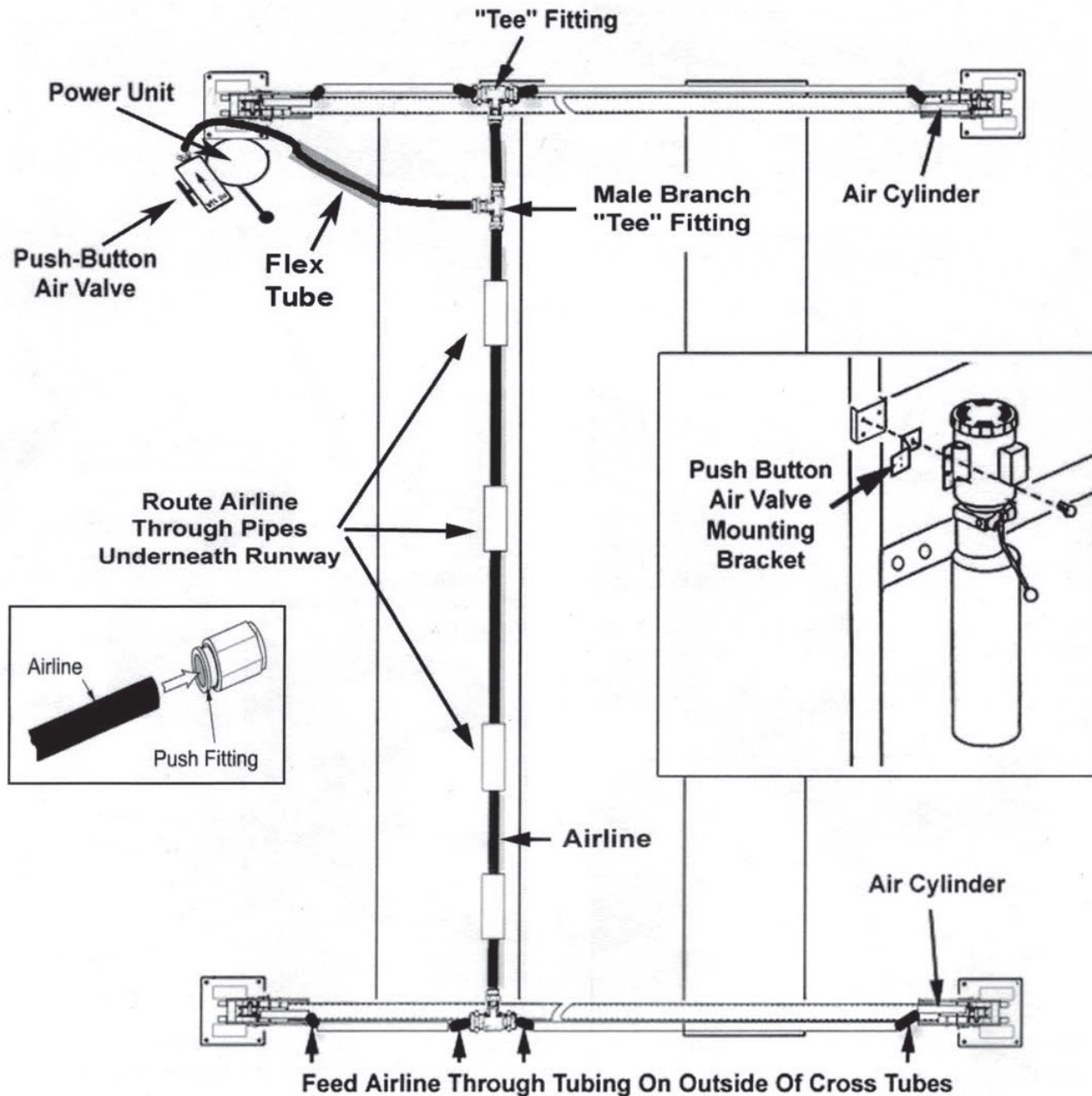

**STEP 10**  
**(Power Unit Hook Up)**

1. Have a certified electrician run the power supply to motor. Refer to the data plate found on the motor for proper power supply and wire size.

**DANGER**

**RISK OF EXPLOSION!**

This equipment has internal arcing or parts that may spark and should not be exposed to flammable vapors. Motor should not be located in a recessed area or below floor level. NEVER expose motor to rain or other damp environments. **DAMAGE TO MOTOR CAUSED BY WATER IS NOT COVERED UNDER WARRANTY.**

**IMPORTANT NOTE:**

**CAUTION** Never operate the motor on line voltage less than 105V. Motor damage may occur which is not covered under warranty. Have a certified electrician run appropriate power supply to motor. Size wire for 32amp circuit. See Motor Operating Data Table.

**IMPORTANT:** Use separate circuit for each power unit. Protect each circuit with time delay fuse or circuit breaker. For single phase 208-240V, use 25amp fuse.

Three phase 208-240V, use 25 amp fuse. For three phase 400V and above, use 15amp fuse. All wiring must comply with NEC and all local electrical codes.

2. Fill the Power Unit with hydraulic oil. Remove the oil vent cap from the power unit and fill the reservoir. Use a non-foaming, non-detergent hydraulic fluid Ten Weight (Hydraulic Oil ISO AW32). The unit will hold approximately 4 to 5 gallons depending on tank size different amounts of fluid may be required.



**Hydraulic Oil ISO AW32 Attributes:**

Flash Point (°F):	350
ISO Viscosity Grade (ISO-VG):	3
Maximum Operating Temperature (° F):	300
Plastic Safe:	Y
Pour Point (°F):	-30

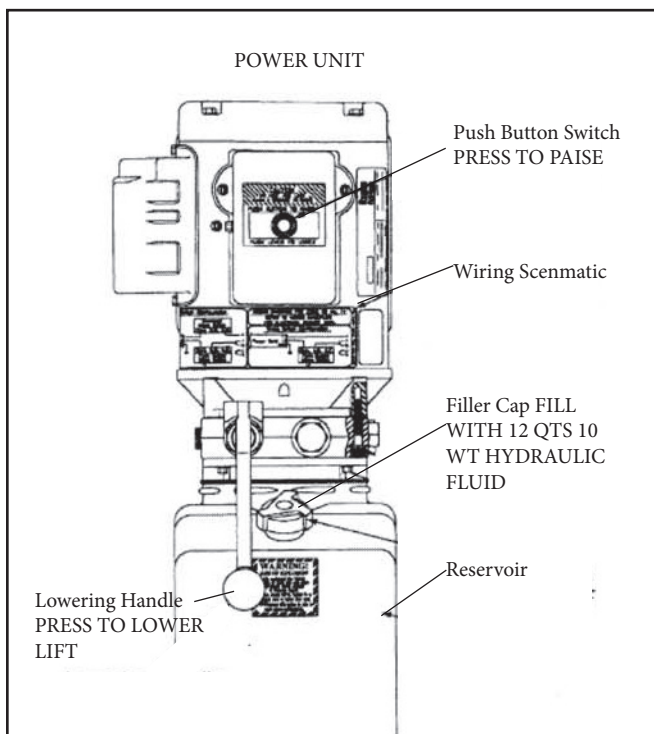

**DANGER**







DO NOT PERFORM ANY MAINTENANCE OR INSTALLATION OF ANY COMPONENTS WITHOUT FIRST ENSURING THAT ELECTRICAL POWER HAS BEEN DISCONNECTED AT THE SOURCE OR PANEL AND CANNOT BE RE-ENERGIZED UNTIL ALL MAINTENANCE AND/OR INSTALLATION PROCEDURES ARE COMPLETED.

**DANGER**  
**HIGH VOLTAGE**



**DANGER**  
LOCK OUT ELECTRICAL SWITCHES BEFORE WORKING ON MACHINERY

**PELIGRO**  
CIERRE TODOS INTERRUPTORES ELÉCTRICOS ANTES DE TRABAJAR EN EL EQUIPO

## IMPORTANT POWER-UNIT INSTALLATION NOTES

-  DO NOT run power unit without oil. Damage to pump can occur.
-  The power unit must be kept dry. Damage to power unit caused by water or other liquids such as detergents, acid etc., is not covered under warranty.
-  Improper electrical connection can damage motor and will not be covered under warranty.
-  Motor works with 60Hz.
-  Use a separate breaker for each power unit.
-  Protect each circuit with time delay fuse or circuit breaker.
-  For 110 volt, single phase, manufacturer recommends using a 32-amp fuse.

## INSTALLATION AND ADJUSTMENT.

-  DO NOT attempt to raise vehicle until a thorough operation check has been completed.
-  ALL WIRING MUST BE PERFORMED BY A CERTIFIED ELECTRICIAN ONLY.
-  SEE WIRING INSTRUCTIONS AFFIXED TO MOTOR FOR PROPER WIRING INSTRUCTIONS.

3. Connect the Electrical hookup to the power unit; 110VAC Single Phase. Use wire capable of supporting a 32-amp circuit. Longer Electrical Runs may require a larger diameter electrical wire.

**WARNING:** A certified electrician must install any and all electrical wiring. Protect each circuit with a time delay fuse or circuit breaker; 110v single phase 60 Hz 32 amp. Requires AWG 10 Wire. Do not adjust power unit pressure relief valve, any tampering will void warranty and may cause catastrophic failure. Failure to heed these warnings may result in injury or death.

**DO NOT attempt to raise vehicle until a thorough operation check has been completed.**

### Single Phase

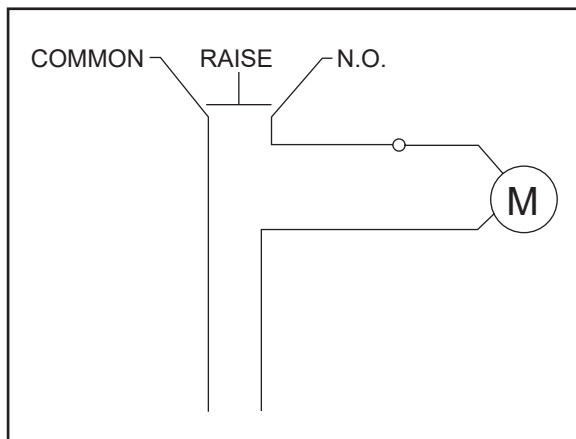

### Three Phase

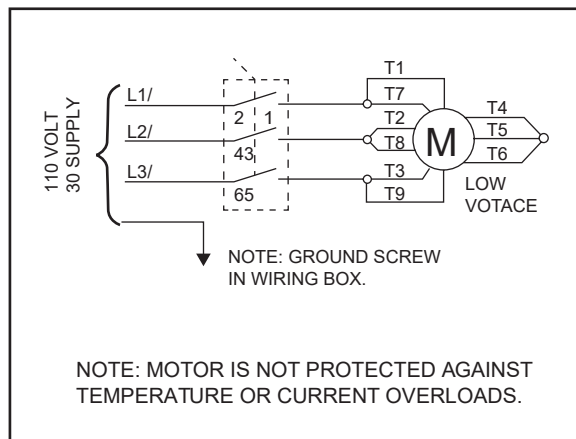

**SEE WIRING INSTRUCTIONS AFFIXED TO MOTOR FOR PROPER WIRING INSTRUCTIONS.**

STEP 11  
(Inspecting The SECONDARY Safety Springs)

**DANGER**

The following steps involve the SECONDARY CABLE SAFETY DEVICE and PRIMARY SAFETY. Failure to follow these steps could result in serious injury or death in the event of cable failure.

1. Inspect the ends of the SECONDARY SAFETY LOCK SPRINGS as shown. Make sure the spring ends are secure at both ends. DO NOT ATTEMPT TO RAISE THE LIFT UNTIL THE SECONDARY SAFETY SPRING ARE ATTACHED AND THE ROLLERS ARE PULLED CLEAR FROM THE LADDER.

Inspect the SECONDARY safety springs as shown. Make sure the spring ends are secure at both ends.

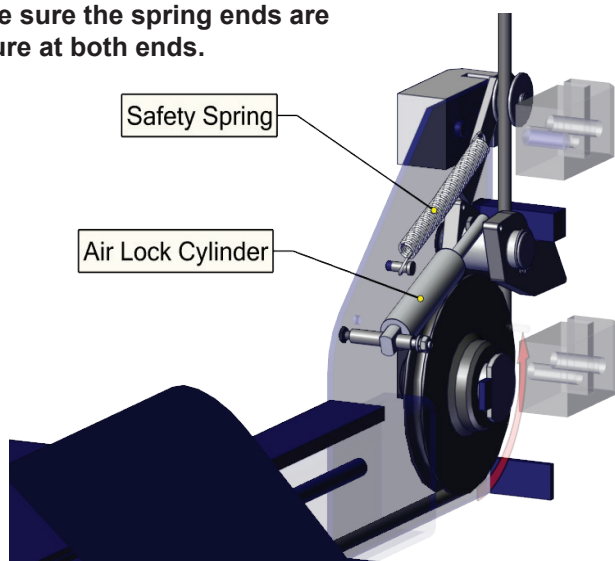

STEP 12  
(Lift Start Up/Final Adjustments)

1. Make sure the Power Unit reservoir is full with 12 quarts of 10-WT hydraulic oil or Dexron-III automatic transmission fluid.

2. Spray the inside of the Columns where the Slide Blocks glide with a light lubricant or WD-40.

3. Test the Power Unit by pressing the push-button switch. If the motor sounds like it is operating properly raise the lift and check all House connections for leaks. If the motor gets hot or sounds peculiar, stop and check all electrical connections.

4. Before proceeding, double-check to make sure all cables are properly positioned within the grooves of ALL Sheaves. Make sure all Cable Sheave retaining Pins and/or Clips are secure.

5. Check to make sure that all Slack Safety Locks are cleared and free,

**SECONDARY safety should be positioned as shown.**

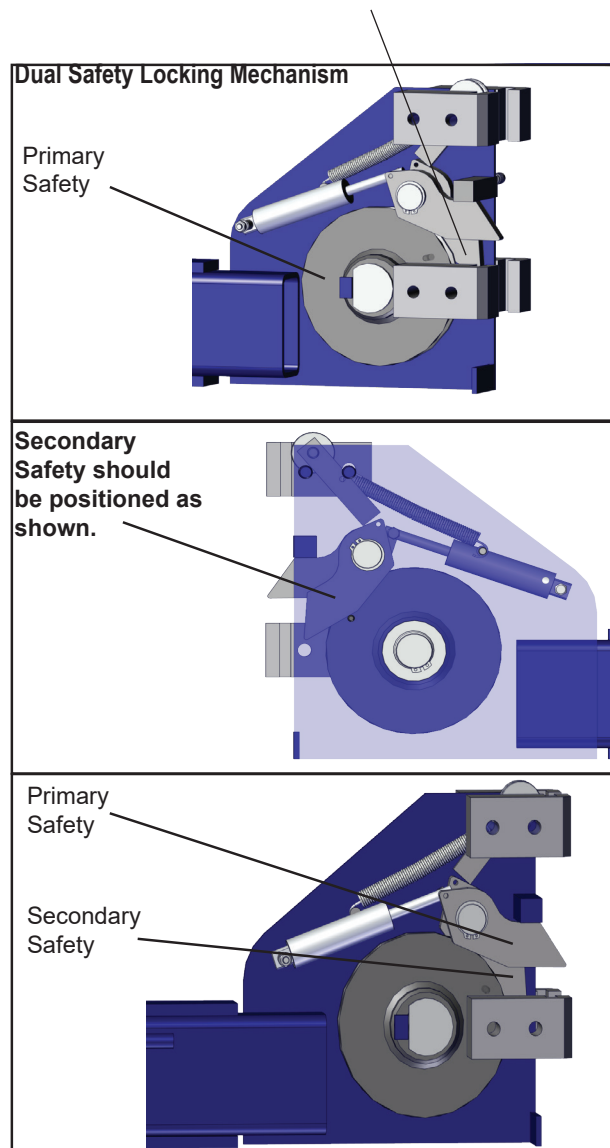

6. Continue pressing the raise button until the Cables get taugt and the lift starts to move.

7. RAISE LIFT UNTIL THE CYLINDER BOTTOMS OUT AND THE LIFT STOPS. ADJUST EACH CABLE SO THAT EACH SAFETY LOCK RESTS AT ONE INCH ABOVE THE TOP SAFETY LOCK POSITION. It may be necessary to tighten or loosen each Cable to reach the proper height. The Cable Nuts MUST be tightened until there is at least one inch of threads protruding through the nut. (see image next page)

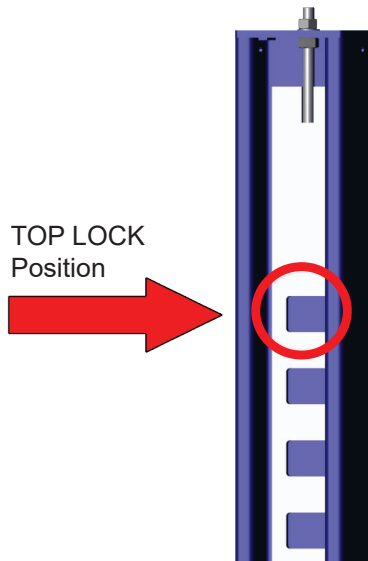

## WARNING

All cable nuts **MUST** be tightened on each end until there is at least one inch of threads protruding through the nut. Failure to do so could result in serious injury or death.

### NOTE:

There will be initial stretching of the cables in the beginning and/or with increased loads. Adjust the Cables as outlined above a week after first use, then every three to six months thereafter depending on usage and/or to compensate for stretch.

8. After connecting the air supply, press the PUSH BUTTON AIR VALVE and check that all Safety Locks are functioning properly. Lower the lift by pressing the push button air valve and power unit lowering valve simultaneously.

9. Run the lift up and down at least three times, **BEFORE ANCHORING THE LIFT DOWN**. This is to bleed the air out of the cylinder and power unit and to help align the lift.

10. Check that lift is square and aligned to measurements before drilling anchor bolts.

11. Align as needed.

# Power Unit

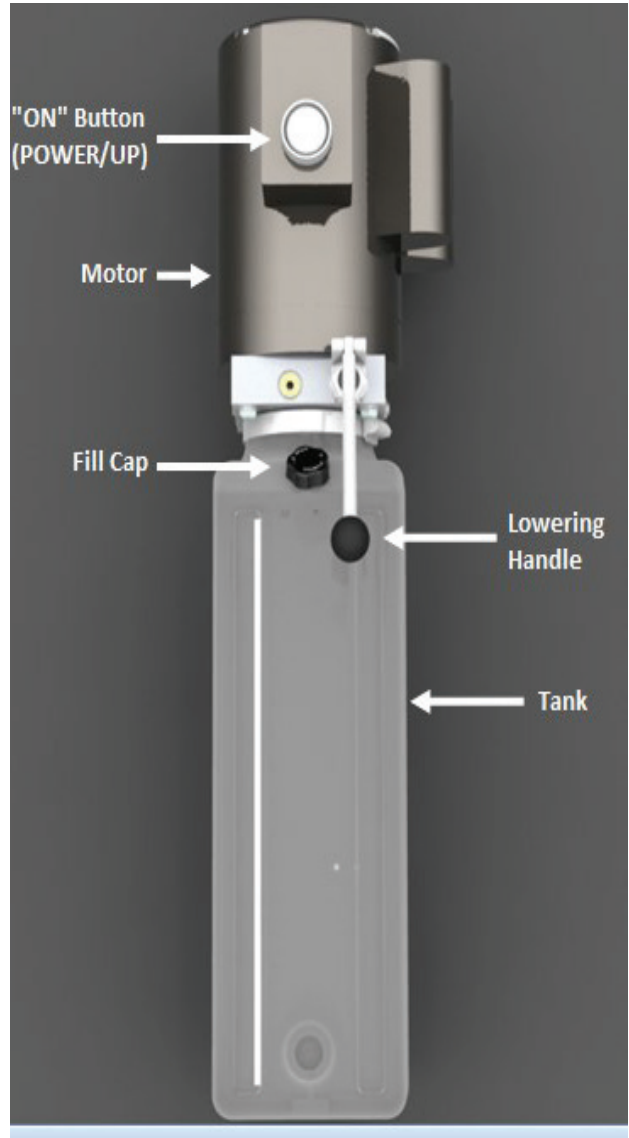

Safety Release Handle	Used to release safety latches when lowering vehicle.
Power "ON" Button	Controls electrical power to the hydraulic power unit. Push to turn-on.
Lowering Handle	Used to relieve hydraulic pressure when pressed to lower lifting carriages.
Fill Cap	Power unit fill Cap for the power unit fluid reservoir. Remove to add fluid.
Tank	Used to store hydraulic fluid.

# EXPANSION ANCHOR INSTALLATION INSTRUCTIONS M16x150

Anchor size is same as drill bit size ( 16mm )

Use a hammer drill with a Carbide tip, 16mm diameter, solid drill bit. The bit tip diameter should be to ANSI Standard B212.15-1994. The Simpson-Tie Strong Bolt 2 wedge anchor is used to resist static, wind and seismic tension and concrete loads in cracked and uncracked concrete applications, with a compressive strength of 3,000psi to 8,500psi. Supports Compliance with 2015, 2012, 2009, and 2006, 2003 International Building Code (IBC); and International Residential Code (IRC). The Strong-Bolt 2 wedge anchors are torque-controlled, mechanical expansion anchors consisting of an anchor body, expansion clip, nut, and washer.

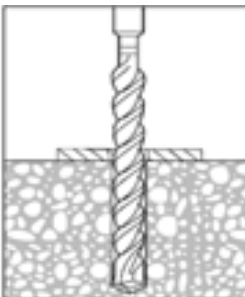
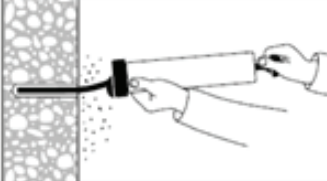
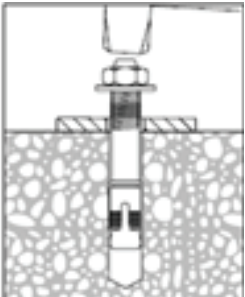
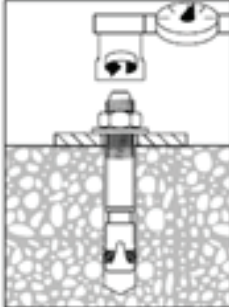
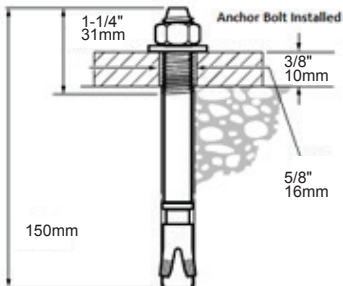
<p><b>Step 1</b></p> 	<p>Hammer Drill a hole to the same nominal diameter as the expansion anchor. The hole depth must exceed the anchor embedment at least 1/4". Use the baseplate as a drilling template to ensure proper anchor locations. (Drill completely through the concrete floor in case movement of the lift is required.)</p>
<p><b>Step 2</b></p> 	<p>Clean hole completely. Remove dirt and dust with the use of a shop vac. or an air compressor.</p>
<p><b>Step 3</b></p> 	<p>Assemble the flat washer and nut flush on the anchor bolt. Drive the expansion anchor into the hole using a hammer. If shimming is required, make sure to leave threads exposed for proper shimming.</p>
<p><b>Step 4</b></p> 	<p>Tighten the nut to the recommended installation torque.</p>
<p><b>Step 5</b></p> 	<p>Installation complete.</p>

Do not disturb, bolt up, or apply load to adhesive anchors prior to the full cure of any adhesive. Metal anchors and fasteners will corrode and may lose load-carrying capacity when installed in corrosive environments or exposed to corrosive materials. There are many environments and materials which may cause corrosion including ocean salt air, fire-retardants, fumes, fertilizers, preservative-treated wood, dissimilar metals, and other corrosive elements. **Finished Diameters for Rotary and Rotary Hammer Carbide Tipped Concrete Drills per ANSI B212.15**

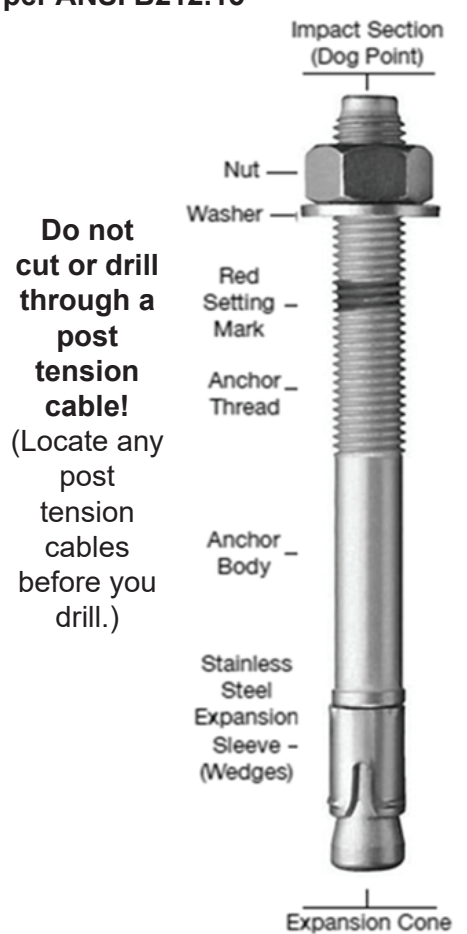

## Installation Instruction for Expansion Anchors

For additional detailed information on foundation requirements see (See Foundation, Anchoring Requirements, and Anchoring Tips Instructions.)

**CAUTION: Anchors must be at least 8" from the edge of the slab or any seam.**

A. Measure Lift Placement. (Recommended using columns as a template before drilling and marking holes.)

B. Keep the drill in a perpendicular line while drilling.

C. Let the drill do the work. Do not apply excessive pressure. Lift the drill up and down occasionally to remove residue to reduce binding.

D. Drill the hole to depth equal to the length of anchor. Note: Drilling all the way through the concrete (recommended) will allow the anchor to be driven through the bottom of foundation if the threads are damaged or if the lift will need to be relocated. (Example A.1)

E. After drilling blow the dust from the holes. (Example A.2)

**F. Repeat Steps 1 through 5 (Qty x 10) after the overhead crossbeam has been installed.**

G. Move column into place carefully. Then complete the following steps.

1) Place flat washer and hex nut over threaded end of M16x150 wedge anchor, leaving approximately 1/16 inch of thread exposed carefully tap anchor (use a hammer). Do not damage threads. Tap anchor into the concrete until nut and flat washer are against base plate.

2) Using the horseshoe shims provided, shim each column base as required until each column is plumb. If one column has to be elevated to match the plane of the other column, add shim plates. Torque anchors to 150 ft.-lbs. Shim thickness MUST NOT exceed 1/2" when using the 150mm long anchors provided with the lift. Adjust the column extensions plumb.

3) Tighten the nut, two or three turns. Check each anchor bolt with torque wrench set to 100 footpounds' torque.

4) Mechanical Anchors: Tighten the expansion anchors several hours after the initial installation. The anchors should be checked with the daily inspection to make sure they are properly maintained.

5) For mechanical anchors that require a specific installation torque: Failure to apply the recommended installation torque can result in excessive displacement of the anchor under load or premature failure of the anchor. These anchors will lose pre-tension after setting due to pre-load relaxation.

**6) If anchors do not tighten to 150 ft.-lbs. installation torque, replace the concrete under each column base with a 4' x 4' x 6-1/2" thick (Recommended 4,000 PSI) 3000psi minimum concrete pad keyed under and flush with the top of existing floor. Allow concrete to cure before installing lifts and anchors (typically 28 days).**

1. Use your measurement markings to center and locate lift. Once this has been accomplished, the column base plate will be used as a guide for drilling the 16mm diameter holes into the concrete. **DRILL THE ANCHOR HOLES ONLY FOR THE “POWERSIDE COLUMN”**, installing anchors as you go. NOTE: Drill through concrete slab (recommended) this will allow the anchor to be driven through the bottom of slab, if the threads are damaged or if the lift will need to be relocated.

**(See Foundation, Anchoring Requirements, and Anchoring Tips Instructions.)**

2. Using a level, check columns for side-to-side plumb and front-to-back plumb. If needed, use shims provided by placing shims underneath the base plate and around the anchor bolt. (Shim thickness must not exceed 1/2”) This will prevent bending the column bottom plates. Tighten the (2) M16 anchor bolts 2 to 3 turns.

To estimate the shim requirements, place a target on floor at each Column position and record the readings, Find the highest of the four locations then find the difference between each of the remaining Columns, This difference is the estimated amount of shim thickness that will be required at each Column,(see Fig)

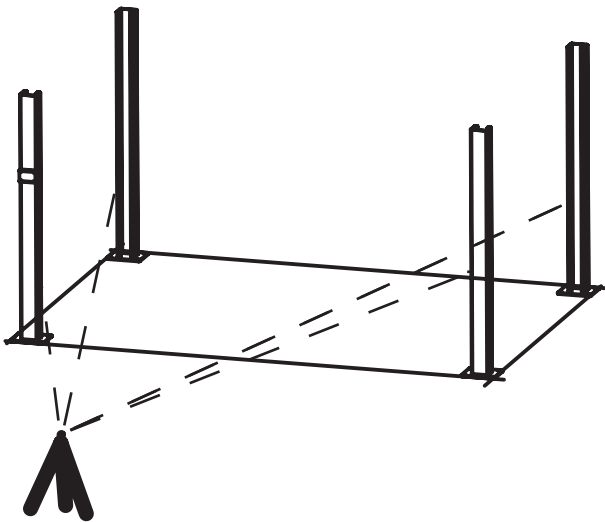

Note. The maximum shim thickness recommended by the factory is no more than 1/2” per Column using shims and anchors provided with the lift

3. Using a tape measure, measure from back corner of the base to the opposite back corner to insure columns are square. After confirming dimensions, install the anchors.

**Note: (Verify column is secure standing alone before beginning next procedures. If needed have another team member secure column standing before performing next steps.)**

Step 14 :Relocating or changing components may cause problems. Each component in the system must be compatible; an undersized or restricted line will cause a drop in pressure. All valve, pump, and hose connections should be sealed and/or capped until just before use. All parts should be supplied from manufacture. Air hoses can be used to clean fittings and other components. However, the air supply must be filtered and dry to prevent contamination. Most important\cleanliness.contamination is the most frequent cause of malfunction or failure of hydraulic equipment.

Step 15 : Check Pulley Cover and Lock Collars: Before proceeding, double check to make sure the locking shaft collars for the crossbeam cable pulleys are tight and secure. Check the pulley cover (2-RIGHT and 2 LEFT) over the shaft located on the pulley side of each crossbeam. CHECK the pulley and cover are firm against the locking shaft collar already in place. Check the additional lock collar on the outside of the shaft is tight and secure. To prevent personal injury or death, crossbeam lock collars must be tight. If they are ever removed -always make sure the locking shaft collars are tight and secure.

Step 16 : Check the crossbeam locking assembly before use. Make sure all bolts and collars are tight. The assembly is prEinstalled from the factory but parts may come loose during shipping.

Step 17 : After installation is completed, before start up, be sure to inspect and tighten all bolts.

Step 18 :Start UpMake sure power unit reservoir is full with IOL of 10-wt hydraulic oil and spray the inside of the columns where the slide blocks glide with a light lubricant.

Step 19 : Initial Operation: Connect power unit 110 v Single Phase Motor to power source . If you are using an extension cord to power source make sure to use 10 AWG wire or above. Neglect will cause breaker to pop.Press the UP SWITCH on the power unit. Raise the lift slowly until all the slack in the cables is taken out. Raise the lift until the safety latch closest to the power unit comes within 25MM to the bottom of the lowest lock position. Tighten the cable-adjusting nut on top of each leg cap until all remaining safety latches come within 25MM to the bottom of the lowest lock position. If cables are adjusted evenly the lift should be raising level and all four safety latches engage or audibly click simultaneously.

IF LIFT DOES NOT RISE: Check hose connections. Fluid should be pumping through the hose. Check fluid level.

NOTE:There will be some initial stretching of the cables in the beginning. It will be necessary to readjust the cables a week or so after first use.

Run the lift up and down a few times to make sure that the safety latches is engaging uniformly and that the safety latch release is functioning properly. Re-adjust if necessary.

When lowering the lift PAY CAREFUL ATTENTION. ALWAYS make sure that all FOUR SAFETY LATCHES are disengaged. If one of the latches locks on descent STOPimmediately and raise until it is clear of the stop and adjust the heim joint rod ends on that latch.

**IMPORTANT: ALL SAFETY LATCHES MUST OPERATE SIMULTAIOUSLY AT THE SAME TIME.**

Synchronizing Equalizing Cables and Locks

A. Without any vehicle on the lift. Cycle the lift up and down several times to insure safety latches engage properly and all air is removed from the hydraulic system. To lower the lift, first raise the lift to clear the safety latches, then pull down the safety release handle to lower the lift.

B. Raise lift and LISTEN. You will hear the lock latches begin to hit and release as the lift is being raised. After 3 or 4 clicks you will hear the latches synchronizing at the same time. If the safety latches are out of synchronization you will have to re-adjust the equalizing cables.

C. If safety latches are out of sync, adjust the cable on the latch that engages first.

D. To adjust, tighten the Long Cable End Terminal on the latch that is engaging first. This could be either the Powerside or Non-Powerside Posts.

E. The safety lock latches and cables should now be synchronized.

F. Equalizing Cables Important Notice: Equalizing Cables must be checked with each daily inspection for equal tension. The cables should always be adjusted so that they are equal tension when resting on the safety locks. Failure keep cables synchronized could cause DANGER and will cause uneven lifting. Equalizing cables should always be adjusted so that safety latches are in sync. Always check that both safety latches are engaging on the appropriate latch.

Step 20 : Install the approach ramps on the entry side of the lift. Drive a vehicle onto the runways then install the rear wheel chocks. Run the lift up and down a few times to insure that the latches are engaging uniformly and that the safety latch release is functioning properly. Re-adjust if necessary.

Step 21 :WITHOUT ANY WEIGHT ON THE LIFT TEST CYCLE THE LIFT TO VERIFY LIFT IS OPERATING AS INTENDED.

Step 22. Lubricate the four inside corners of the columns with heavy duty bearing grease.

Step 23. Complete Post Installation Procedure.

• SEE “OPERATOR TRAINING and SAFE PRACTICES” and “HOW TO OPERATE LIFT” prior to first use.

OPERATION Do not use this lift unless you know the proper operation of the lift and its safety devices, and the hazards involved. See Safety Instructions.

1. Drive the vehicle onto lift platform. Set the vehicle’s parking brake and leave the transmission in park/ gear. Chock the vehicle’s wheels.

2. Stand clear -Push the top UP button to raise vehicle to desired height. Push the rod handle on the power unit to open release valve and lower tracks until it stops, check the all four latches for full engagement in the rack on each leg.

3. To lower - push UP button to raise - rotate latch release rod handle and hold-push rod handle on power unit to lower. Warning: Make sure all four latches release - if not STOP, raise higher until latch is clear, if it does not work now the hem in -tie rod end on that latch needs adjustment.

4. Any hydraulic oil leakage, unusual noise, or excessive wear must be fixed before using lift.  
PRE OPERATION CHECK The user should perform daily check. ATTENTION! LOOK OUT!

Inspect Daily check list and safety latch system is very important - the discovery of device failure before needed could save you from expensive property damage, lost production time, serious personal injury and even death.

1. Check safety latches for free movement and full engagement with rack.

2. Check hydraulic connections, and hoses for leakage.

3. Check cables for damage and that they are in the groove on cable sheave.

4. Check lock collars at all rollers and sheaves.

5. Check bolts, nuts, and screws and tighten.

6. Check wiring & switches for damage.

7. Keep base plate free of dirt, grease or any other corrosive substances.

SEE PROPER SAFETY AND OPERATING PROCEDURES.

**Special Note:**

**This lift should be anchored to the floor at all times when raising a vehicle.**

## POST INSTALLATION PROCEDURE:

- ✓ Check boxes to verify work has been completed

	Electric wired by a professional technician.
	Power unit functioning properly.
	With the in lift in the lowered position, check that the hydraulic fluid level is full. If needed, add oil as described in the Installation Instruction section of this manual.
	Check for “no” hydraulic leaks.
	Check that all posts are square and plumb.
	Lubricate posts with grease. Lubricate the four inside corners of the columns with heavy-duty bearing grease as needed.
	Inspect lifting arms making sure they are functioning properly.
	Visually inspect safeties for proper operation. Check all arm adjusting locks for proper operation.
	Check lifting carriage gear restraints securely fastened.
	Inspect all arms pins making sure they are properly secure.
	Inspect that arm pads are in good condition.
	Check that lift arms are level and synchronized.
	Check equalizer cable tension, and adjust if necessary, see manual instructions.
	Check all cables connections, bolts and pins to ensure proper mounting and torque.
	Check safety latch synchronization: Safety latches should click at the same time. If necessary, adjust equalizing cables as described in the Installation Instruction section of this manual.
	Lubricate all Cable Sheaves.
	Check tightness of all bolts, nuts, pins, and hardware. Re-tighten as needed. See installation manual torque specified ratings.
	Inspect all anchors bolts and retighten if necessary. Re-torque as needed. See installation manual for instructions.
	Inspects all roll pins and sheave pins are in proper alignment and secured.
	Make a visual inspection of all moving parts and check for excessive signs of wear.
	Check for no overhead obstructions.
	If lift is equipped with an overhead stop bar, check for proper operation.
	Test mercury switch operation.
	Check all warning labels and power unit safety stickers are in good condition. Replace all caution, warning or safety related decals on the lift if unable to read or missing. Reorder labels from manufacturer.
	All components functioning properly.
	All integral moving parts lubricated.
	Working area clean.
	Operation, maintenance and safety manuals in designated location.

## **INSTRUCTIONS TO READ THE MANUAL(S) THOROUGHLY BEFORE INSTALLING, OPERATING, SERVICING, OR MAINTAINING THE LIFT.**

PLEASE READ THE ENTIRE CONTENTS OF THIS MANUAL AND THE ANSI/ALI ALIS, SAFETY REQUIREMENTS FOR INSTALLATION AND SERVICE FOR AUTOMOTIVE LIFTS LITERATURE, PRIOR TO INSTALLATION AND OPERATION. BY PROCEEDING WITH THE LIFT INSTALLATION AND OPERATION YOU AGREE THAT YOU FULLY UNDERSTAND THE FULL CONTENTS OF THIS MANUAL. THIS MANUAL MUST BE READ BY ALL USERS. FAILURE TO OPERATE THIS EQUIPMENT AS DIRECTED MAY CAUSE INJURY OR DEATH.

### **OPERATOR TRAINING AND SAFE PRACTICES**

#### **Owner/Employer/User :**

- **SHALL** ensure that lift operators are qualified and that they are trained in the safe use and operation of the lift using the manufacturer's operating instructions; ALI/SM 10-1, ALI Lifting it Right Safety Manual; AL-ST-10 ALI Safety Tips Card; ANSI/ALI ALOIM-2008 (R2013) American National Standard for Automotive Lifts - Safety Requirements for Operation, Inspection and Maintenance, ALI/WL Series, ALI Uniform Warning Label Decals/Placards and in the case of frame engaging lifts, ALI/LP-GUIDE, Vehicle Lifting Points/Quick Reference Guide for Frame Engaging Lifts.
- **SHALL** establish procedures to periodically inspect the lift in accordance with the lift manufacturer's instructions or ANSI/ ALI ALOIM-2008 (R2013) American National Standard for Automotive Lifts - Safety Requirements for Operation, Inspection and Maintenance; and The Employer Shall ensure that lift inspectors are qualified and that they are adequately trained in the inspection of the lift.
- **SHALL** establish procedures to periodically maintain the lift in accordance with the lift manufacturer's instructions or ANSI/ALI ALOIM-2008 (R2013) American National Standard for Automotive Lifts-Safety Requirements for Operation, Inspection and Maintenance; and The Employer Shall ensure that lift maintenance personnel are qualified and that they are adequately trained in the maintenance of the lift.
- **SHALL** maintain the periodic inspection and maintenance records recommended by the manufacturer or ANSI/ALI ALOIM-2008 (R2013) American National Standard for Automotive Lifts-Safety Requirements for Operation, Inspection and Maintenance.
- **SHALL** display the lift manufacturer's operating instructions; ALI/SM 10-1, ALI Lifting it Right safety manual; AL-ST-10 ALI Safety Tips card; ANSI/ALI ALOIM-2008 (R2013) American National Standard for Automotive Lifts-Safety Requirements for Operation, Inspection and Maintenance; and in the case of frame engaging lifts, ALI/LP-GUIDE, Vehicle Lifting Points/Quick Reference Guide for Frame Engaging Lifts; in a conspicuous location in the lift area convenient to the operator
- **SHALL** provide necessary Lockout/Tagout means for energy sources per ANSI Z244.1-2003 (R2014), Safety Requirements for the Lockout/Tagout of Energy Sources, before beginning any lift repairs.
- **SHALL** not modify the lift in any manner without the prior written consent of the manufacturer
- **WILL NOT** modify the lift in any manner without the prior written consent of the manufacturer.
- Manufacturer has provided Labels that follow the guidance of ANSI Z535.1, *American National Standard for Safety Color Code*.

## OPERATOR TRAINING AND SAFE PRACTICES, CONT.

- Manufacturer has provided Label symbols that follow the guidance of ANSI Z535.3, *American National Standard, Criteria for Safety Symbols*.
- Manufacturer has provided Labels designs that follow the guidance of ANSI Z535.4, *American National Standard for Product Safety Signs and Labels*.
- **Precautions and Safety should always be followed when installing and operating this lift.**
- **ONLY TRAINED** and **AUTHORIZED PERSONNEL** should operate the lift. Do not allow customers or unauthorized personnel to operate the lift or remain in the lift area.
- **Review regularly** the safety rules and guidelines with personnel. All non-trained personnel should be kept away from work area. Never let non-trained personnel come in contact with, or operate lift.
- **Be aware. Watch what you are doing. Use common sense.**
- **Understand** the vehicle lift operating controls before use.
- **DO NOT** leave the operational controls while the lift is still in motion.
- **DO NOT** stand in front of the vehicle or in the bay when vehicle is being loaded or driven into position.
- **DO NOT** attempt to work on the vehicle or go near vehicle when lift is being raised or lowered.
- **ALWAYS** stay clear of lift when raising or lowering vehicle.
- **ALWAYS** clear the area if a vehicle is in danger of falling.
- **KEEP** hands and feet clear. Remove hands and feet from any moving parts. Keep feet clear of lift when lifting or lowering to avoid bodily harm or any pinch points.
- **DO NOT** raise a vehicle on the lift until the installation is completed as described in this manual.
- **DO NOT raise or lower the vehicle unless tools, materials and people are clear. Clean up grease and oil spills immediately.** When the lift is being lowered, make sure everyone is standing at least six feet away. Be sure there are no jacks, tools, or equipment, left under the lift before lowering. Always lower the vehicle down when the area is safe and clear.
- **INSPECT THE LIFT DAILY.** Do not operate if potential problems have been identified or lift malfunctions. Do not operate if lift has damaged or broken components. Check all moving parts for any type of damage that may affect misalignment or operation of lift.
- **NEVER** walk under or work under the lift unless all safety locks are completely engaged.
- A daily inspection of the lift should be completed prior to any use. Safety mechanisms, operating controls, lifting arms, ramps and any other critical parts should be inspected prior to using the lift.

## OPERATOR TRAINING AND SAFE PRACTICES, CONT.

- **ALWAYS KNOW YOUR LOAD LIMIT.** Use caution so that you do not overload the lift. It is important that you know the load limit. To check the rated capacity, decals are located on one of the lift columns or contact the manufacturer for replacements labels. The hydraulic system on this lift is not designed to be a load holding device. Mechanical safety locks must be engaged before proceeding under the lift, with vehicle servicing, or system maintenance. Never override operating controls. This is unsafe and will void the warranty, before driving a vehicle between the columns, position all arms to insure unobstructed entry. Do not hit or run over arms as this could damage the lift and/or vehicle.
- **ALWAYS make sure you have proper overhead clearance.**
- **WARNING! RISK OF EXPLOSION.** This equipment has internal arcing or sparking parts which should not be exposed to any flammable vapors.
- **DO NOT** locate this machine in a recessed area or below floor level. **ALLOW FOR PROPER DRAINAGE.**
- **USE LIFT CORRECTLY.** Use lift in the proper manner. Never use lifting adapters other than what is approved by the manufacturer.
- Positioning the vehicle is very important. Only trained technicians should position the vehicle on the lift. Never allow anyone to stand in the path of the vehicle as it is being positioned.
- Keep the area around the lift clean and free of debris.
- Some vehicle maintenance and repair activities may cause the vehicle to shift. Follow the manufacturer's guidelines when performing these operations. The use of jack stands or alternate lift points may be required when completing some repairs. Special care must be used when lifting light duty trucks. Optional truck adapters may be required for each manufacturer's recommended lifting points. Always use these lifting points. Running boards and other installed accessories may also require optional adapters. Insure vehicle is balanced when lifting light duty trucks, failure to do so can cause injury and/or death.
- Removal or installation of heavier parts can change the vehicle's center of gravity on the lift resulting in a critical load shift. The vehicle may then be unstable. Plan ahead for this possibility to insure continued safety and refer to the vehicle manufacturers' service manual for recommended procedures.
- **DO NOT** remove any heavy component from vehicle that may cause excessive weight shift.
- **ALWAYS** keep the lift area free of obstructions and debris.
- **NEVER** raise a vehicle with passengers inside. Before lowering a vehicle, check the lift and lift area and remove all obstructions. Before removing vehicle from the lift or lift area, position arms to the drive through position and confirm an unobstructed exit.
- Use of jack stands or other load supporting devices will help in preventing load shifts. Manufacturer suggests that jack stands or other load supporting devices are used at all times for additional security. Use additional lifting equipment or stands when removing or installing heavy vehicle components.

## OPERATOR TRAINING AND SAFE PRACTICES, CONT.

- **ALWAYS** Make sure the vehicle's center of gravity is always safe before raising vehicle. Any points of contact on vehicle that are not in good contact with lifting pads or contact with lift should always be double checked. Always make sure the vehicle is secure before lifting using vehicle manufacturers' recommended lifting points.
- Large vehicles, such as limousines, RV's, and long wheelbase vehicles, may not be suitable for lifting on this equipment.
- **DO NOT** rock or tip the vehicle while working on or around lift.
- **VERIFY** that all safety latches are engaged and lowered on to the safety ladders before any attempt is made to work on or near vehicle.
- **NEVER** override self-operating lift controls.
- **NEVER** remove any safety related components parts from the lift. Do not use the lift if any safety related components parts are damaged or missing.
- **DO NOT** block open or override self-closing lift controls; they are designed to return to the "Off" or Neutral position when released.
- **DO NOT** remove or disable arm restraints.
- **DO NOT** hit or run over lift arms or adapters. This could damage lift or vehicle. Before driving vehicle into lift bay, position arms and adapters to provide unobstructed entrance onto lift.
- **USE THE LIFT ONLY AS DESCRIBED IN THIS MANUAL.**
- Use only manufacturer's recommended attachments.
- The troubleshooting and maintenance procedures described in this manual can be done by the lift's owner/employer. Any other procedure should only be performed by trained lift service personnel. These restricted procedures include, but are not limited to, the following: cylinder replacement, carriage and safety latch replacement, arm replacement, overhead structure replacement, or electrical troubleshooting/repair.
- **NEVER** use the lift on curved or tubular bumper. Do not lift curved bumpers as this will result in slipping off and falling, causing serious injury or death. A bumper lift will lift most vehicles with curved bumpers or plastic bumpers.
- **PAY ATTENTION** when walking under a vehicle that is raised on the vehicle lift.

## OPERATOR TRAINING AND SAFE PRACTICES, CONT.

### DANGERS:

- To reduce the risk of personal injury, keep hair, loose clothing, fingers, and all body parts away from moving parts.
- To reduce the risk of electric shock, do not use the lift when wet. The lift should not be exposed to the rain.
- To reduce the risk of fire, do not operate equipment in the close proximity of open containers containing flammable liquids (example: Gasoline, flammable solvents).
- Anyone who will be in the vicinity of the lift when it is in use should familiarize themselves with following Caution, Warning, and Safety related decals supplied with this lift and replace them if they are illegible or missing.
- Anyone who will be in the vicinity of the lift when it is in use should read and refer to publications supplied with this lift.

## HOW TO OPERATE THE LIFT

1. Familiarize yourself with the lift before use.
  2. Precautions and Safety should always be followed when operating this lift.
  3. **ONLY TRAINED** and **AUTHORIZED PERSONNEL** should operate the lift. Do not allow customers or unauthorized personnel to operate the lift or remain in the lift area during use.
  4. Understand the vehicle lift operating controls before use. Make sure all operators have been trained and review the OPERATOR TRAINING AND SAFE PRACTICES of this manual before using lift.
  5. Always allow a minimum 2-second delay between motor starts. Failure to comply may cause switch and/or motor to burnout. This could cause serious damage to the equipment and/or personal property. Power unit must be wired by a qualified electrician. This power unit should be located at least 18 inches (460 mm) above the floor. Motor duty cycle is one full lifting operation 10 minutes.
  6. This equipment has internal arcing or sparking parts which should not be exposed to flammable vapors.
  7. Use only recommended ISO AW32 or AW46 hydraulic oils. Oil must be changed after the first week of operation and once every 12 months or as needed. Add extra oil as needed.
  8. See the instructions in the maintenance section of this manual how to add oil to the Power Unit.
  9. Have a complete understanding of the carriage safety lock mechanisms.
    - ✓ The “LOCKED position” will be used when raising the lift. This function should always work automatically.
    - ✓ The “UN-LOCKED position” will be used when lowering a lift or adjust**Note:** DO NOT remove or tamper with the design of the locking assembly.  
*Failure to use locks as designed or forcing a lock to stay in the open position during use will be grounds for immediate termination of this warranty and any manufacturer liabilities.*
  10. **ALWAYS** ensure the safeties are engaged before any attempt is made to work on or near the vehicle.
  11. **NEVER** leave lift in elevated position unless the safeties are engaged.
  12. **NEVER** operate the lift with any person or equipment below the vehicle.
  13. **NEVER** exceed the rated lift capacity.
  14. **DO NOT PERMIT ELECTRIC MOTOR TO GET WET!** Motor damage caused by dampness is not covered under warranty.
  15. **ALWAYS** position lifting, ramps, adapters and accessories properly out of the way before pulling the vehicle into or out of the bay. Failure to do so could damage the vehicle and/or the lift.
  16. After positioning the vehicle, set the emergency brake, make sure the ignition is off, the doors are closed, overhead obstructions are cleared.
-  **Warning:**
17. Make sure vehicle is not front or rear heavy. The center of balance should be midway between adapters.



**DANGER:**

20. Before raising a vehicle make sure vehicle is positioned correctly so all four corners of vehicle are stationary with wheel stops. Position all lift points. See vehicle manufacturers' recommended lifting points. **Raise lift slowly until all pads contact the vehicle. Check all pads for complete and secure contact with the vehicle. Check all arm restraints to insure they are engaged properly. Check that the vehicle is stable on the lift.** Only after confirming these procedures, raise the lift to desired working height.

**NOTE:**

21. Some specialty or modified vehicles cannot be raised on a four-post frame engaging lift. Contact YOUR vehicle manufacturer for raising or jacking details.
22. **ALWAYS** load vehicle on lift carefully. Position the lifting ramps, adapters and accessories to the vehicle manufacturer's recommended pickup points. Raise the lift until contact is made with the vehicle. Make sure that the lifting arms, ramps, adapters and accessories have properly engaged the vehicle before raising the lift to a working height.

**DANGER:** Check adapters for secure contact with vehicle before operating.

23. **DO NOT RAISE OR LOWER ANY VEHICLE UNLESS TOOLS, MATERIALS AND PEOPLE ARE CLEAR. CLEAN UP GREASE AND OIL SPILLS IMMEDIATELY.** When the lift is being lowered, make sure everyone is standing at least six feet away. Be sure there are no jacks, tools, or equipment, left under the lift before lowering. Always lower the vehicle down when the area is safe and clear.

**DANGER:**

24. Check the fitment of the "half-moon" gear restraints on each lifting arm. Check for proper engagement of the arm restraints (arm locks) before raising a vehicle. The safety gear restraints should fully engage the gear restraints on the arm automatically.

**Note:** Regularly verify that Allen Bolts on gear restraints are tight and secure.

**DANGER:**

25. Some vehicles may have the manufacturer's Service Garage Lift Point locations identified by triangle shape marks on the undercarriage (reference ANSI/SAE J2184). Also, there may be a label located on the right front door jamb area showing specific vehicle lift points.

**Note:** Also provided with your purchase is a copy of the ALI LP - QUICK REFERENCE GUIDE VEHICLE LIFTING POINTS FOR FRAME ENGAGING LIFTS, this is a guide for basic lifting point locations on your vehicle. For actual vehicle recommended lifting points consult your vehicle manufacturer.

## **TO RAISE THE LIFT,**

26. Adjust the vehicle so that it is positioned with the center of gravity midway between the lift
27. Press the power "on" button.
28. A clicking sound will be heard as the lift raises. These are the crossbeam locks that will securely hold a vehicle.
29. Once the desired height has been achieved slightly raise the crossbeams just above the last latch position and slowly lower the load on the safety locks.
30. Verify that both Safety locks have been engaged before beginning work.
31. Use of jack stands or other load supporting devices will help in preventing load shifts.
32. Use additional lifting equipment or stands when removing or installing heavy vehicle components.
33. Make sure the vehicle's center of gravity is always safe before raising vehicle. Any points of contact on vehicle that are not in good contact with lift should always be double checked. Always make sure the vehicle is secure before lifting using only your vehicle manufacturer's recommended lifting points.

## **TO LOWER THE LIFT,**

34. To lower the lift, first raise the lift to clear the safety latches, press the power "on" button, then pull down the safety release handle to lower the lift. The carriages should now be in the free UN-LOCKED position.
35. Simultaneously hold the Safety crossbeam Locks in the UN-LOCKED Position and press the lowering control valve on the power unit.
36. Lower the lift slowly until reach the lowest retracted position.

**CUSTOMER DAILY MAINTENANCE INSPECTION RECORD**

**DATE:** \_\_\_\_\_

✓ Check boxes to verify work has been completed

	Power unit functioning properly.
	With the lift in the lowered position, check that the hydraulic fluid level is full. If needed, add oil as described in the Installation Instruction section of this manual.
	Check for “no” hydraulic leaks
	Check that all posts are square and plumb.
	Lubricate posts with grease. Lubricate the four inside corners of the columns with heavy-duty bearing grease as needed.
	Inspect lifting arms making sure they are functioning properly.
	Visually inspect safeties for proper operation. Check all arm adjusting locks for proper operation.
	Check that all lifting carriage gear restraints are securely fastened, and that screws are tightened.
	Inspect all arms pins making sure they are properly secure.
	Inspect that arm pads are in good condition, replace if worn.
	Check that lift arms are level and synchronized.
	Check equalizer cable tension, and adjust if necessary, see manual instructions.
	Check all cables connections, bolts and pins to ensure proper mounting and torque.
	Inspect all cables for any damage, breaks, worn out, or corrosion. Replace cables if needed.
	Check safety latch synchronization: Safety latches should click at the same time. If necessary, adjust equalizing cables as described in the Installation Instruction section of this manual.
	Lubricate all Cable Sheaves.
	Check tightness of all bolts, nuts, pins, and hardware. Re-tighten as needed. See installation manual torque specified ratings.
	Inspect all anchors bolts and retighten if necessary. Re-torque as needed. See installation manual for instructions.
	Inspects all roll pins and sheave pins are in proper alignment and secured
	Make a visual inspection of all moving parts and check for excessive signs of wear.
	Check for no overhead obstructions
	If lift is equipped with an overhead stop bar, check for proper operation.
	Test mercury switch operation
	Check all warning labels and power unit safety stickers are in good condition. Replace all caution, warning or safety related decals on the lift if unable to read or missing. Reorder labels from manufacturer.
	All components functioning properly
	All integral moving parts lubricated
	Working area clean
	Operation, maintenance and safety manuals in designated location

**⚠ DANGER:** If anchor bolts are loose or any component of the lift is found to be defective, **DO NOT USE THE LIFT.**

- **ALWAYS** keep lift components clean.
- **ALWAYS** if oil leakage is observed, place lift out of service and contact Customer Service.
- **ALWAYS** contact a local service representative if electrical problems develop.
  - **ALWAYS** keep bolts tight.
- **ALWAYS** replace ALL FAULTY PARTS before lift is put back into operation.
- Refer to ANSI/ALI ALOIM booklet for periodic inspection checklist and maintenance log sheet.

*Replace damaged, broken or wearing parts with lift manufacturer’s approved OEM parts only.*

**NOTES:** \_\_\_\_\_  
 \_\_\_\_\_  
 \_\_\_\_\_

PRINT COPY PAGES FOR DAILY RECORDS

## **CUSTOMER MAINTENANCE INSPECTION AND LUBRICATION**

If you use and maintain your equipment properly, it will give you many years of service. Follow the maintenance instructions carefully to keep your equipment in good working condition. Never perform any maintenance on the equipment while it is under a load. Refer to the CUSTOMER DAILY MAINTENANCE INSPECTION RECORD for proper inspections to be completed by user daily.

### **Inspection**

You should inspect the product for damage, wear, broken or missing parts (e.g.: pins) and that all components function before each use. Follow lubrication and storage instructions for optimum product performance.

### **Cleaning**

If the moving parts of the equipment are obstructed, use cleaning solvent or another good degreaser to clean the equipment. Remove any existing rust, with a penetrating lubricant.

### **Lubrication**

This equipment will not operate safely without proper lubrication. Using the equipment without proper lubrication will result in poor performance and damage to the equipment. Some parts in this equipment are not self-lubricating. Inspect the equipment before use and lubricate when necessary. After cleaning, lubricate the equipment using a high grade penetrating lubricant.

Use a good lubricant on all moving parts.

For light duty use, lubrication is needed once a month.

For heavy and constant use, lubrication is recommended every week.

**NEVER USE SANDPAPER OR ABRASIVE MATERIAL ON THESE SURFACES!**

See the Wire Rope Section for details on lubrication wire ropes and cables.

### **Rust Prevention:**

Check hydraulic cylinder ram assemblies daily for any signs of rust or corrosion. Without a load lift the equipment as high as it goes and look under and behind all components. If signs of rust are visible clean as needed.

### **Grease Fittings**

Some models contain grease fittings that will regularly need to be greased and lubricated.

### **Additional Lubrication:**

1. Periodically check the hydraulic cylinders for signs of rust or corrosion. Clean as needed and wipe with an oil cloth. **NEVER USE SANDPAPER OR ABRASIVE MATERIAL ON THESE SURFACES!**
2. When not in use, lower the lift to the fully retracted position. Failure to do so can cause rust and corrosion to degrade the life of the hydraulic cylinders.

## CUSTOMER MAINTENANCE

### TO ADD HYDRAULIC OIL:

1. Lower the lift to its lowest resting position.
2. Remove the oil plug.
3. Fill the oil case until oil level is just beneath the lower rim of the oil fill hole.
4. Replace oil plug.
5. Perform the Air Purge Procedure.

### TO REPLACE HYDRAULIC OIL:

Hydraulic oil should only be changed when equipment is fully lowered. Use only recommended ISO AW32 or AW46 hydraulic oils. Oil must be changed after the first week of operation and once every 12 months or as needed.

1. Lower the lift to its lowest resting position.
2. Remove power unit from lift.
3. Remove the oil fill plug.
4. Turn the power unit on its side to drain old oil from the oil fill hole.
5. Ensure the tank is clean before refilling.
6. Remount the power unit on the lift. Fill the oil case until oil level is just beneath the lower rim. Keep dirt and other foreign materials clear when pouring.
7. Replace oil plug.
8. Perform Air Purge Procedure.

### **ADDITIONAL WARNINGS:**

- ✓ DO NOT USE MOTOR OIL, HYDRAULIC BRAKE FLUID, ALCOHOL, GLYCERINE, DETERGENT, OR DIRTY OIL, TURBINE OIL, TRANSMISSION FLUID, OR GLYCERIN. IMPROPER FLUID CAN CAUSE FAILURE OF THE HYDRAULIC SYSTEM AND HAS THE POTENTIAL FOR SUDDEN AND IMMEDIATE LOSS OF LOAD.
- ALWAYS ONLY USE A HIGH GRADE ANTI-FOAMING HYDRAULIC OIL.
- USE OF A NON-RECOMMENDED FLUID CAN CAUSE DAMAGE TO THE HYDRAULIC SYSTEM.
- ✓ AVOID MIXING DIFFERENT TYPES OF FLUID AND DISPOSE OF HYDRAULIC FLUID IN ACCORDANCE WITH LOCAL REGULATIONS.

### **HYDRAULIC OIL PERFORMANCE ADDITIVES:**

Description: Add (1-qt)

Additives perform to Lower friction for some hydraulic systems

Attributes: Relieves "stick-slip" on noisy hydraulic cylinders (eg. Humming noise or excecssive vibrating),

Recommended Application: .95-liter bottle recommended. Used as a friction modifier to help reduce noise level.

**Caterpillar Equipment part number: 1U-9891**

### **SYSTEM AIR PURGE PROCEDURE**

 **IMPORTANT: BEFORE FIRST USE** perform the following Air Purge Procedure to remove any air that may have been introduced into the hydraulic system. This step is to be completed without any weight or vehicles on the lift.

- Refer to page 40 for additional information.

## **SERVICE MAINTENCE AND SERVICE CALLS**

The manufacturer can provide on-site service to your lift product by a qualified lift service technician. The owner may be responsible for all costs and direct payment to the contractor at the time the work is completed. It is the owner's responsibility to return any parts to the manufacturer for warranty validation. Repairs should only be completed by a qualified lift technician.

**For additional lift maintenance and issues please contact a TORIN CUSTOMER SERVICE REPRESENTATIVE or a LOCAL TRAINED LIFT SERVICE TECHNICIAN.**

**DO NOT assume how to repair lift.**

**If product is "Binding" contact a customer service agent.**

### **Binding**

If the product binds while under a load, use equipment with equal or a larger load capacity to lower the load safely to the ground. After un-binding; clean, lubricate and test that equipment is working properly. Rusty components, dirt, or worn parts can be causes of binding clean and lubricate the equipment as indicated in the lubrication section. Test the equipment by lifting without a load. If the binding continues, contact Customer Service.

# ELECTRICAL LOCKOUT PROCEDURE

## Purpose

This procedure establishes the minimum requirements for the lockout of energy that could cause injury to personnel by the operation of lifts in need of repair or being serviced. All employees shall comply with this procedure. See ANSI/ASSE Z244.1-2003 (R2014) Control of Hazardous Energy Lockout/Tagout and Alternative Methods for additional information.

## Responsibility

The responsibility for assuring that this procedure is followed is binding upon all employees and service personnel from outside service companies (i.e., authorized installers, contactors, etc.). All employees shall be instructed in the safety significance of the lockout procedure by the facility owner/manager. Each new or transferred employee along with visiting outside service personnel shall be instructed by the owner/manager (or assigned designee) in the purpose and use of the lockout procedure.

## Preparation

Employees authorized to perform lockout shall ensure that the appropriate energy isolating device (i.e., circuit breaker, fuse, disconnect, etc.) is identified for the lift being locked out. Other such devices for other equipment may be located in close proximity of the appropriate energy isolating device. If the identity of the device is in question, see the shop supervisor for resolution. Assure that proper authorization is received prior to performing the lockout procedure.

## Sequence of Lockout Procedure

1. Notify all affected employees that a lockout is being performed for servicing or maintenance and that the lift must be shut down and locked out to perform the servicing or maintenance
2. Unload the subject lift (remove vehicle). Shut it down and assure the disconnect switch is "OFF" if one is provided on the lift.
3. The authorized lockout person operates the main energy isolation device removing power to the lift being taken out of service. Stored or residual energy (such as capacitors, springs, elevated machine members, hydraulic systems, air, or etc.) must be dissipated or restrained by methods such as grounding, repositioning, blocking, bleeding down, etc. If this is a lockable device, the authorized lockout person places the assigned padlock on the device to prevent its unintentional reactivation. An appropriate tag is applied stating the person's name, at least 3" x 6" in size, an easily noticeable color, and states not to operate device or remove tag. If this device is a non-lockable circuit breaker or fuse, replace circuit with a "dummy" device and tag it appropriately as mentioned above.
4. Ensure that the equipment is disconnected from the energy sources' by first checking that no personnel are exposed, then verify the isolation of the equipment by operating the push button or other normal operating controls' or by testing to make certain the equipment will not operate. Be sure to return any switches to the "OFF" position.
5. The equipment is now locked out and ready for the required maintenance or service.

## Restoring Equipment to Service

1. Check the lift and the immediate area around the lift to ensure that nonessential items have been removed (clear all tools, vehicles and personnel) and that the completion of all lift components are operationally intact.
2. The authorized person can now remove the lock (or dummy circuit breaker or fuse) and tag. Activate the energy isolating device so that the lift may again be placed into operation.

## Rules for Using Lockout Procedure

All employees are required to comply with the restrictions and limitations imposed upon them during the use of lockout. The authorized employees are required to perform the lockout in accordance with this procedure. All employees, upon observing a piece of lifting equipment which is locked out to perform servicing or maintenance shall not attempt to start, energize, or use that machine or equipment. The Lockout Procedure should be used whenever the lift is being repaired or serviced, waiting for repair when current operation could cause possible injury to personnel, or for any other situation when unintentional operation could injure personnel. No attempt shall be made to operate the lift when the energy isolating device is locked out.



## WIRE ROPE INSPECTION, USE, AND CARE

The following information is **NOT** a complete discussion of wire rope.

**WHAT FOLLOWS IS A BRIEF OUTLINE OF THE BASIC INFORMATION REQUIRED TO SAFELY USE WIRE ROPE AND WIRE ROPE SLINGS.**

Equalizing and Lifting Cables should be replaced every three years when visible signs of damage are apparent. **DO NOT USE THE LIFT WITH DAMAGED OR WORN CABLES.**

Wire Rope should be maintained in a well-lubricated condition at all times. Wire rope is only fully protected when each wire strand is lubricated both internally and externally. Excessive wear will shorten the life of the wire rope. The manufacturer suggests using a wire rope lubricant that penetrates to the core of the wire rope, providing long term lubrication. All wire rope, sheaves and guide rollers in continuous service should be observed during normal operation and visually as per the scheduled maintenance. A complete and thorough inspection of all ropes in use must be made as below and all rope which has been idle for a period of a month or more should be given a thorough inspection before it is put back into service. Factors such as abrasion, wear, fatigue, corrosion, improper winding and kinking are often of greater significance in determining if a wire rope is usable.

1. Wire rope **WILL FAIL IF WORN OUT, OVERLOADED, MISUSED, DAMAGED** or **IMPROPERLY MAINTAINED**.
2. In service, wire rope loses strength and work capability. Abuse and misuse increase the rate of loss.
3. The **NOMINAL STRENGTH**, sometimes called **CATALOG** strength, of a wire rope applies **ONLY** to a **NEW, UNUSED** rope.
4. The Nominal Strength of a wire rope **SHOULD BE CONSIDERED** the straight line pull which will **ACTUALLY BREAK** a new, **UNUSED** rope. The Nominal Strength of a wire rope should **NEVER BE USED AS ITS WORKING LOAD**.
5. **WIRE ROPES WEAR OUT**. The strength of a wire rope begins to decrease when the rope is put in use, and continues to decrease with each use.
6. **NEVER OVERLOAD A WIRE ROPE**. This means **NEVER USE** the rope where the load applied to it is greater than the working load determined by dividing the Nominal Strength of the rope by the appropriate Design Factor.
7. **NEVER "SHOCK LOAD"** a wire rope. A sudden application of force or load can cause both visible external damage and internal damage. There is no practical way to estimate the force applied by shock loading a rope. The sudden release of a load can also damage a wire rope.
8. Lubricant is applied to the wires and strands of a wire rope when it is manufactured. This lubricant is depleted when the rope is in service and should be replaced periodically.
9. Regular, periodic **INSPECTIONS** of the wire rope, and keeping of **PERMANENT RECORDS**. The purpose of inspection is to determine whether or not a wire rope may continue to be safely used on that application. Inspection criteria, including number and location of broken wires, wear and elongation, should be recorded. **IF IN DOUBT, REPLACE THE ROPE**. An inspection should include verification that none of the specified removal criteria for this usage are met by checking for such things as:
  - Surface wear: Normal and unusual.
  - Broken wires: Number and location.
  - Reduction in diameter.
  - Rope stretch (elongation).
  - Integrity of end attachments.In addition, an inspection should include the condition of sheaves, drums and other apparatus with which the rope makes contact.

10. When a wire rope has been removed from service because it is no longer suitable for use, IT MUST NOT BE RE-USED ON ANOTHER APPLICATION.
11. Every wire rope user should be aware of the fact that each type of fitting attached to a wire rope has a specific efficiency rating which can reduce the working load of the rope assembly or rope system, and this must be given due consideration is determining the capacity of a wire rope system.
12. Some conditions that can lead to problems in a wire rope system include:
  - Sheaves that are too small, worn or corrugated cause damage to a wire rope.
  - Broken wires mean a loss of strength.
  - Kinks permanently damage a wire rope and must be avoided.
  - Wire ropes are damaged by knots, and wire ropes with knots must never be used.
  - Environmental factors such as corrosive conditions and heat can damage a wire rope.
  - Lack of lubrication can significantly shorten the useful service life of a wire rope.
  - Contact with electrical wires and the resulting arcing will damage a wire rope.

**Recommended Lubrication Product:**

A high-grade penetrating lubricant for wire rope, chain and cable that contain a petroleum solvent that carry the lubricant into the core of the wire rope, then evaporates, leaving behind a heavy lubricating film to protect and lubricate each strand. A penetrating lubricant is essential in any lubrication program as most wire rope fails from the inside out.

Check and lubricate all guide rollers, sheaves and hardware that are in operational contact are visually checked for wear and lubrication

**HOW OFTEN TO INSPECT**

- Lifting cables should be visually inspected at least once each day when in use, as suggested by American Petroleum Institute (API) RP54 guidelines.
- Any lifting cables that have met the criteria for removal must be immediately replaced.

**WHEN TO REPLACE LIFTING CABLES DUE TO BROKEN WIRES**

- Lifting cables should be removed from service when you see six randomly distributed broken wires within any one lay length, or three broken wires in one strand within one lay length.

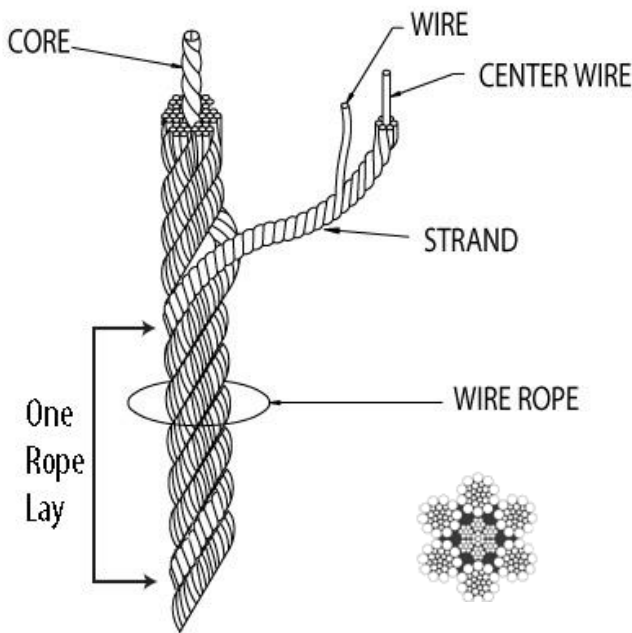

- OTHER REASONS TO REPLACE WIRE ROPE**
- Corrosion that pits the wires and/or connectors.
  - Evidence of kinking, crushing, cutting, bird-caging or a popped core.
  - Wear that exceeds 10% of a wire's original diameter.
  - Evidence of heat damage.

## HOW TO INSPECT WIRE ROPE

- I. Relax the rope to a stationary position and move the pick-up points off the sheaves. Clean the surface of the wire rope with a cloth this will allow you to see breaks. (Use a stiff wire brush, if necessary.)
- II. Flex the rope to expose any broken wires hidden in the channels between the strands.
- III. Visually check for any broken wires. One way to check for crown breaks is to run a cloth along the rope to check for possible snags.
- IV. With an awl tool, probe between wires and strands and lift any wires that appear loose. Evidence of internal broken wires may require a more extensive rope examination. (IF IN DOUBT REPLACE CABLES)
- V. Check for layer to layer crushing or individual wires that may have been displaced from their normal position.
- VI. Check Sheaves for deeply corrugated sheaves that may also be causing damage to wire ropes. Replace sheaves if needed.
- VII. Replace wire rope if any failing condition is found.

- A lubricant suited to the conditions under which the rope is operating should then be applied. Several methods are suggested, and the one most suited to the installation and lubricant being used may be chosen. It is better to lubricate lightly and frequently than heavily and infrequently. For best results lubricate to core of cables.
- Improve rope performance and overall effectiveness
- Check all guide rollers, sheaves and hardware that are in operational contact are visually checked for wear and lubrication.
- Visually Inspect and Apply lubricants to all contact points using a heavy weight lubricant using the methods as described: spray, pump, brush or hand lubrication.

For Additional Information see "Wire Rope User's Manual 4<sup>th</sup> Ed."

**Failure to read, understand, and follow these instructions may cause death or serious injury. Read and understand these instructions before using the lift.**

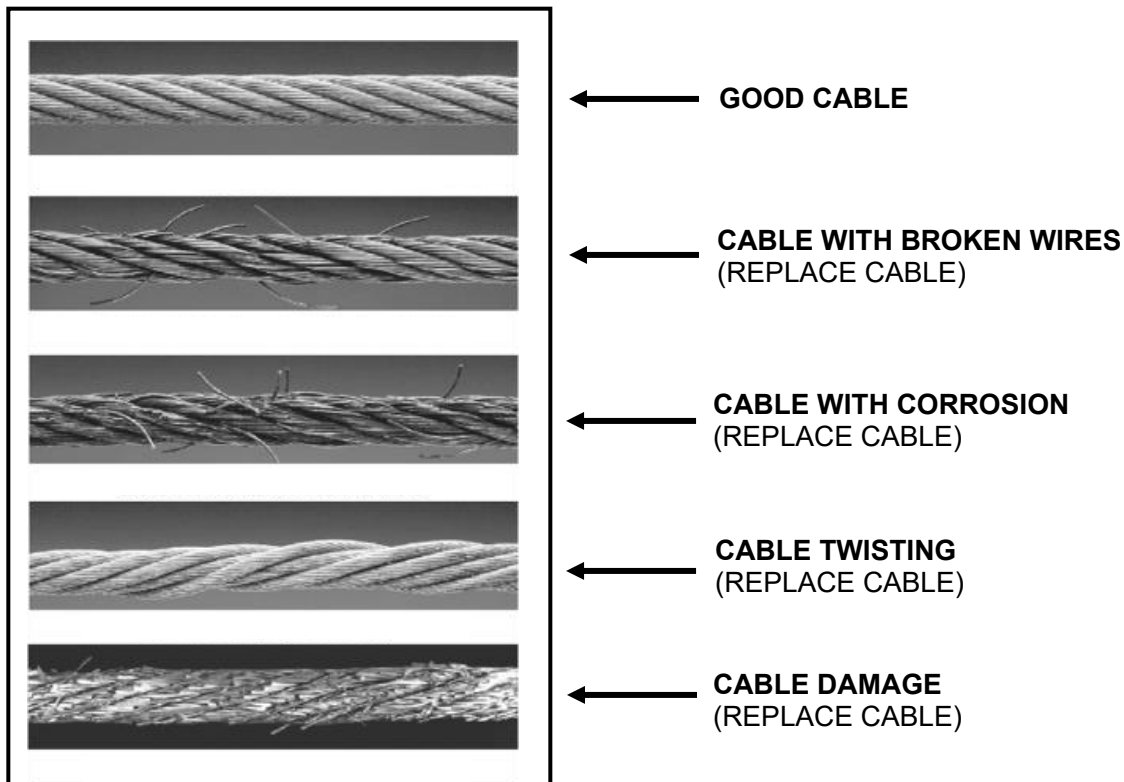

## TROUBLESHOOTING

### LIFT WILL NOT RAISE

	Air is in the oil	<ul style="list-style-type: none"> <li>• Check for proper oil level. The oil level should be up to the bleed screw in the reservoir with the lift all the way down.</li> <li>• Bleed cylinders. See Installation Manual</li> <li>• Oil seal damaged or cocked. Replace oil seal around pump shaft.</li> <li>• Inlet screen clogged. Clean inlet screen or replace</li> </ul>
	Cylinder is binding	<ul style="list-style-type: none"> <li>• Contact Customer Service.</li> </ul>
	Cylinder leaks internally	<ul style="list-style-type: none"> <li>• Contact Customer Service</li> </ul>
	Lift does not raise and lower smoothly	<ul style="list-style-type: none"> <li>• Reposition vehicle for a more even weight distribution</li> <li>• Check the four inside corners of the two columns for roughness. Any rust or burrs must be removed with emery cloth.</li> <li>• Lubricate the four corners with heavy duty bearing grease.</li> <li>• Use a level to check the columns for vertical alignment both side to side and front to back. Shim the columns as necessary per the Installation Instruction section of this manual.</li> <li>• Check the oil level</li> <li>• Inspect that there is no air in the hydraulic lines. Bleed the hydraulic system as described in the Installation Instruction section of this manual.</li> </ul>
	Lowering valve is leaking	<ul style="list-style-type: none"> <li>• Contact Customer Service</li> </ul>
	Motor runs backwards	<ul style="list-style-type: none"> <li>• Check if motor is wired correctly. Compare wiring of motor to electrical diagram on drawing.</li> <li>• Check wall outlet voltages and wiring. Make sure unit and wall outlet are wired properly.</li> <li>• Contact Customer Service</li> </ul>
	Motor run backward under pressure	<ul style="list-style-type: none"> <li>• Contact Customer Service</li> </ul>
	Power Unit will not stop running	<ul style="list-style-type: none"> <li>• Switch is damaged. Turn off power to the lift and replace switch</li> </ul>
	Pump is damaged	<ul style="list-style-type: none"> <li>• Contact Customer Service</li> </ul>
	Pump will not prime	<ul style="list-style-type: none"> <li>• Check for proper oil level. The oil level should be up to the bleed screw in the reservoir with the lift all the way down.</li> <li>• Flush release valve to get rid of. Hold release handle down and start unit allowing possible contamination it to run for 15 seconds.</li> <li>• Oil seal damaged or cocked. Replace oil seal around pump shaft.</li> <li>• Replace with new part.</li> <li>• Check pump-mounting bolts. Bolts should be 15 to 18 ft. lbs.</li> <li>• Inlet screen clogged. Clean inlet screen or replace.</li> <li>• Check wall outlet voltages and wiring. Make sure unit and wall outlet are wired properly.</li> <li>• Contact Customer Service</li> </ul>
	Relief valve leaks	<ul style="list-style-type: none"> <li>• Contact Customer Service</li> </ul>
	Voltage to the motor is incorrect	<ul style="list-style-type: none"> <li>• Check if motor is wired correctly. Compare wiring of motor to electrical diagram on drawing.</li> <li>• Check wall outlet voltages and wiring. Make sure unit and wall outlet are wired properly.</li> <li>• Contact Customer Service</li> </ul>
	The power unit does not run	<ul style="list-style-type: none"> <li>• Check electrical supply breaker or fuse</li> <li>• Check to see if limit switch is being contacted by a tall vehicle</li> <li>• Check micro-switch and connections in motor control box</li> <li>• Check voltage to the motor</li> <li>• Check micro-switch and connections on the overhead switch</li> </ul>
	The power unit runs but does not raise the lift	<ul style="list-style-type: none"> <li>• Check the oil level</li> <li>• Check that the lowering valve is not stuck open</li> <li>• Check the connections and components on the suction side of the pump</li> </ul>
	The power unit raises the lift empty but will not lift a vehicle	<ul style="list-style-type: none"> <li>• Make sure the vehicle is not above the rated capacity of the lift</li> <li>• Make sure the vehicle is positioned properly</li> <li>• Clean the lowering valve by running the power unit for 20 seconds while holding the lowering valve open</li> <li>• Check the motor voltage</li> </ul>

## TROUBLESHOOTING

### MOTOR WILL NOT RUN

Fuse is blown	<ul style="list-style-type: none"> <li>• Check for correct voltage. Compare supply voltage with voltage on motor name tag. Check that the wire is sized correctly. Requires AWG 10 for 30 Amps.</li> <li>• Check motor is wired correctly. Compare wiring of motor to electrical diagram on drawing.</li> <li>• Don't use extension cords. The size of the conductors should be such that the voltage drop would not exceed 3% to the farthest outlet for power. Do not run motor at 115 VAC – damage to the motor will occur.</li> <li>• Reset circuit breaker/fuse. Reset circuit breaker/fuse.</li> <li>• Contact Customer Service.</li> </ul>
Limit switch is burned out	<ul style="list-style-type: none"> <li>• Check for correct voltage. Compare supply voltage with voltage on motor name tag. Check that the wire is sized correctly. Requires AWG 10 for 30 Amps.</li> <li>• Check motor is wired correctly. Compare wiring of motor to electrical diagram on drawing.</li> <li>• Don't use extension cords. The size of the conductors should be such that the voltage drop would not exceed 3% to the farthest outlet for power. Do not run motor at 115 VAC – damage to the motor will occur.</li> <li>• Contact Customer Service.</li> </ul>
Mercury switch is burned out	<ul style="list-style-type: none"> <li>• Check for correct voltage. Compare supply voltage with voltage on motor name tag. Check that the wire is sized correctly. Requires AWG 10 for 30 Amps.</li> <li>• Check motor is wired correctly. Compare wiring of motor to electrical diagram on drawing.</li> <li>• Don't use extension cords. The size of the conductors should be such that the voltage drop would not exceed 3% to the farthest outlet for power. Do not run motor at 115 VAC – damage to the motor will occur.</li> <li>• Contact Customer Service</li> </ul>
Motor is burned out	<ul style="list-style-type: none"> <li>• Check for correct voltage. Compare supply voltage with voltage on motor name tag. Check that the wire is sized correctly. Requires AWG 10 for 30 Amps.</li> <li>• Check motor is wired correctly. Compare wiring of motor to electrical diagram on drawing.</li> <li>• Don't use extension cords. The size of the conductors should be such that the voltage drop would not exceed 3% to the farthest outlet for power. Do not run motor at 115 VAC – damage to the motor will occur.</li> <li>• Replace with a new part.</li> <li>• Contact Customer Service</li> </ul>
Voltage to the motor is not correct	<ul style="list-style-type: none"> <li>• Check for correct voltage. Compare supply voltage with voltage on motor name tag. Check that the wire is sized correctly. Requires AWG 10 for 30 Amps.</li> <li>• Check motor is wired correctly. Compare wiring of motor to electrical diagram on drawing.</li> <li>• Check wall outlet voltage and wiring. Make sure unit and wall outlet is wired properly. Motor must run at 110 VAC.</li> </ul>

### LIFT LOWERS SLOWLY OR NOT AT ALL

Lift lowers slowly down	<ul style="list-style-type: none"> <li>• Check for oil leaks</li> <li>• Clean the lowering valve by running the power unit for 20 seconds while holding the lowering valve open. Repeat this procedure a few times</li> <li>• Clean the check valve seat</li> </ul>
The cylinders are binding	<ul style="list-style-type: none"> <li>• Contact Customer Service.</li> </ul>
The release valve is clogged	<ul style="list-style-type: none"> <li>• Check the hydraulic oil. Use a clean hydraulic oil, Use only a recommended ISO AW32 or AW46 hydraulic oil. If the hydraulic oil is contaminated, replace with a clean hydraulic oil and clean entire system.</li> <li>• Clean the release valve. Thoroughly wash the release valve in solvent and blow out with air.</li> <li>• Contact Customer Service.</li> </ul>
The lift will only lower completely to 1" from the floor	<ul style="list-style-type: none"> <li>• Adjust cable as needed to assure that cables have not been over tightened and check that both safety latches are disengage.</li> <li>• Check that the safety latches are disengaged</li> </ul>

## TROUBLESHOOTING

### WILL NOT RAISE LOADED LIFT

Lift is overloaded	<ul style="list-style-type: none"> <li>• Check the weight of the vehicle. Compare the weight of vehicle to weight limit of the lift.</li> <li>• Contact Customer Service.</li> </ul>
Slow Lifting and/or oil foaming up	<ul style="list-style-type: none"> <li>• Check that oil used meets the specification in the Installation Instruction section of this manual</li> <li>• Tighten all suction line fittings</li> <li>• Not enough oil in tank and air has been transferred into the hoses and cylinder. (Complete bleed system and replace oil.)</li> </ul>
There is air in the oil	<ul style="list-style-type: none"> <li>• Check the oil level. The oil level should be just below the fill cap in the reservoir with the lift at its lowest resting position.</li> <li>• Check and tighten all hydraulic fittings. Check that hydraulic hose assembly is not clogged with debris.</li> <li>• The oil seal is damaged or cracked. Replace the oil seal and re-install.</li> <li>• Bleed cylinders. See Instruction Manual.</li> </ul>
The cylinder is binding	<ul style="list-style-type: none"> <li>• Contact Customer Service.</li> </ul>
The cylinder leaks internally,	<ul style="list-style-type: none"> <li>• Contact Customer Service.</li> </ul>
Lowering valve leaks	<ul style="list-style-type: none"> <li>• Check the oil level. The oil level should be just below the fill cap in the reservoir with the lift at its lowest resting position.</li> <li>• Flush the release valve. To do this hold release valve handle down and start unit. Allow the power unit to run for 15 seconds.</li> <li>• Contact Customer Service.</li> </ul>
The motor runs backwards	<ul style="list-style-type: none"> <li>• Check that the motor is wired correctly. Compare the wiring of motor to electrical diagram on power unit drawing.</li> <li>• Check the outlet voltage and wiring. Make sure that the power unit and the wall outlet are wired properly.</li> <li>• Contact Customer Service.</li> </ul>
The pump is damaged	<ul style="list-style-type: none"> <li>• Contact Customer Service.</li> </ul>
The pump will not prime	<ul style="list-style-type: none"> <li>• Check the oil level. The oil level should be just below the fill cap in the reservoir with the lift at its lowest resting position.</li> <li>• Check and tighten all hydraulic fittings. Check that hydraulic hose assembly is not clogged with debris.</li> <li>• The oil seal is damaged or cracked. Replace the oil seal and re-install.</li> <li>• Bleed cylinders. See Instruction Manual.</li> <li>• The inlet screen is clogged. Clean the inlet screen or replace the screen.</li> <li>• Contact Customer Service.</li> </ul>
The relief valve leaks	<ul style="list-style-type: none"> <li>• Contact Customer Service.</li> </ul>
Voltage to the motor is not correct	<ul style="list-style-type: none"> <li>• Contact Customer Service.</li> <li>• Check that the motor is wired correctly. Compare the wiring of motor to electrical diagram on power unit drawing.</li> <li>• Check the outlet voltage and wiring. Make sure that the power unit and the wall outlet are wired properly.</li> </ul>

### LIFT WILL NOT STAY UP

Air in is the oil	<ul style="list-style-type: none"> <li>• Check the oil level. The oil level should be just below the fill cap in the reservoir with the lift at its lowest resting position.</li> <li>• The oil seal is damaged and cocked. Replace oil seal around the pump shaft.</li> <li>• Bleed cylinder. Refer to Instruction Manual.</li> </ul>
The power unit check valve leaks	<ul style="list-style-type: none"> <li>• Contact Customer Service.</li> </ul>
Cylinders is leaking internally	<ul style="list-style-type: none"> <li>• Contact Customer Service.</li> </ul>
Lowering valve leaks	<ul style="list-style-type: none"> <li>• Check the oil level. The oil level should be just below the fill cap in the reservoir with the lift at its lowest resting position.</li> <li>• Flush the release valve. Hold release handle down and start unit allowing it to run for 15 seconds.</li> <li>• Contact Customer Service.</li> </ul>
Leaking fittings	<ul style="list-style-type: none"> <li>• Check the entire hydraulic system for leaks. Check that all hydraulics fittings are tightened and inspects all hoses.</li> </ul>

# TROUBLESHOOTING

## OTHER ISSUES

	Safety lock are out of adjustment	<ul style="list-style-type: none"> <li>• If the equalization or lifting cables are out of adjustment, the carriages are out of sync. When the lift is at full rise, one of the safety latches may not have the clearance to disengage and allow the lift to lower. Read adjust cables as described in manual.</li> </ul>
	At full rise the safety latch will not disengage and the lift cannot be lowered	<ul style="list-style-type: none"> <li>• Check oil level</li> <li>• If the equalization cables are out of adjustment, the carriages are out of sync. When the lift is at full rise, one of the safety latches may not have the clearance to disengage and allow the lift to lower</li> </ul>
	Anchors continually work loose	<ul style="list-style-type: none"> <li>• If holes were drilled too large, relocate the lift per the Installation Instruction section of this manual.</li> <li>• Floor is not sufficient to provide the necessary resistance. Remove an area of concrete and re-pour as described in the Expansion Anchor Installation Instruction section of this manual.</li> </ul>
	Humming or vibration coming from cylinders	<ul style="list-style-type: none"> <li>• Perform Air purge procedure</li> <li>• Add (1qt) of a Hydraulic Oil Performance Additives: Attributes: Relieves "stick-slip" on noisy hydraulic cylinders (eg. Humming noise or exxcessive vibrating), Recommended Application: .95-liter bottle recommended. Used as a friction modifier to help reduce noise level. <b>Caterpillar Equipment part number: 1U-9891</b></li> <li>• Check for leaking cylinders or seal damage</li> </ul>

**⚠ DANGER:**

**IF A VEHICLE BECOMES STUCK ON THE LIFT IN THE AIR, FOLLOW ALL OPERATION INSTRUCTIONS AS SHOWN IN THE OPERATING INSTRUCTIONS AND TROUBLESHOOTING SECTION OF THIS MANUAL. IF AFTER OBSERVING THAT ALL MECHANICAL LOCKS ARE RELEASED AND THE LIFT STILL FAILS MOVE FOLLOWING ALL STANDARD OPERATING PROCEDURES, IMMEDIATELY STOP USING THE LIFT AND CONTACT CUSTOMER SERVICE FOR FURTHER INSTRUCTIONS.**

For all other issues, questions, or concerns please contact a Customer Support Service Representative. Contact Torin® Customer Service directly by telephone at 1-888-44-TORIN (1-888-448-6746) 8:00am – 5:00pm Pacific Time, Monday – Friday.

# 4-POST PARTS ASSEMBLY LIST

QJY4040H			QJY4030H		QJY4030		QJY4040		
Part #	Description	Qty	Part #	Qty	Part #	Qty	Part #	Qty	
1	QJY4030H.1.1	POST - POWERSIDE	1	QJY4030H.1.1	1	QJY4030.1.1	1	QJY4040.1.1	1
2	GB5781	BOLT M8X22	4						
3	QJY4040-06	HYDRAULIC AND AIR HOSE BRACKET	1						
4	GB93	SPRING WASHER 8	4						
5	GB97	WASHER 8	4						
6	GB6170	NUT M8	4						
7	QJY4040-08	FIXED PLATE	1						
8	GB97	WASHER 4	2						
9	GB6170	NUT 4	2						
10		VALVE	1						
11	GB818-85	BOLT M4X35	2						
12		PUMP	1						
13	QJY4040.4	CROSSTUBE SINGLE SHEAVE	1	QJY4030.3	1	QJY4030.4	1	QJY4040.4	1
14	GB5782	BOLT M12X80	8						
15	GB93	SPRING WASHER 12	8						
16	GB97	WASHER 12	8						
17	GB6170	NUT M12	8						
18	QJY4040H.5	RUNWAY - POWERSIDE	1	QJY4030H.5	1	QJY4030.5	1	QJY4040.5	1
19	QJY4040H.6	RUNWAY - NON-POWERSIDE	1	QJY4030H.6	1	QJY4030.6	1	QJY4040.6	1
20	QJY4040.9	RUNWAY - STOP PLATE	2						
21	QJY4040-05	AXIS	4						
22	QJY4030H.2.1	POST - NON-POWERSIDE	3						
23	QJY4040.7	EXTENSION PART	2						
24	QJY4040.3.1	CROSSTUBE DOUBLE SHEAVE	1	QJY4030.4	1	QJY4030.3	1	QJY4040.3	1
25	QJY4040.1.3	POST TOP PLATE	4						
26	GB93	SPRING WASHER 8	8						
27	GB97	WASHER 8	8						
28	GB6170	HEX NUT M8	8						
29	GB5782	BOLT M8X22	8						
30	GB6170	HEX NUT M16	4						
31	GB97.1	WASHER 16	4						
32	QJY4030H.1.2	LADDER LOCK BAR	4	QJY4030H.1.2	4	QJY4040.1.2	4	QJY4040.1.2	4
34	GB6170	NUT M6	4						
35	GB889.1	LOCK NUT M16	4						
36	QJY4040H.5-01	HYDRAULIC HOSE 3/8" JIS (#6 STRAIGHT END TO 90° END)	1	QJY4030H.5-01	1	QJY4040.5-07	1	QJY4040.5-07	1
37	QJY4040.5-01	HYDRAULIC FITTING 90° #6 BOSS O- RING FITTING (SAE 9/16" TO 3/8" JIS)	1						
38	QJY4040.3-05	SLIDE BLOCK	16						
39	GB5780	BOLT M6X80	8						
40	QJY4040.7-04	WHEEL	8						
41	GB97.1	WASHER 6	8						
42	QJY4040.3-08	PRIMARY LOCK	4						
43	GB894	EXTERNAL RETAINING RING 26mm	8						
44	QJY4040.3.2	SECONDARY LOCK	4						
45		AIR CYLINDER	4						
46	QJY4040.3-04	PULLEY 38mm	4						
47	GB894	RING 10	4						
48	QJY4040.3-07	INSURANCE AXIS	4						
49	GB819.2	BOLT M6X25	4						
50	GB93	SPRING WASHER 6	4						

# 4-POST PARTS ASSEMBLY LIST

QJY4040H				QJY4030H		QJY4030		QJY4040	
	Part #	Description	Qty	Part #	Qty	Part #	Qty	Part #	Qty
51	GB97	WASHER 6	4						
52	GB6170	NUT M6	4						
53	QJY4040.3-03	SHORT SLEEVE	4						
54	QJY4040.3-01	EXTENSION SPRING	4						
55	QJY4040.3-02	LONG SLEEVE	4						
56	GB5782	BOLT M6X70	4						
57	QJY4040.3.3	WIRE WHEEL OARTS	4						
59	QJY4040.3.4	SHEAVE (PULLEY) - SINGLE (with/BUSHING 3248)	6						
60	GB95	WASHER M30	4						
61	GB894	RING 32	4						
62	GB889	NYLON INSERT HEX LOCK NUT M18	4						
63	GB95	FLAT WASHER M18	4						
64	QJY4040.5.5	SHEAVE (PULLEY) - DOUBLE (with/BUSHING 3266)	2						
65	QJY4040.5-04	SLEEVE	2						
66	QJY4040.5.4	SHEAVE SHAFT	4						
67	GB819	SCREW M6X20	4						
70	GB6170	NUT M24	2						
71	GB95	WASHER M24	1						
72	QJY4040.5-02	CABLE RETAINER PLATE	1						
73	QJY4040.5.2	CYLINDER GUIDE BLOCK	1						
74	GB6170	NUT M6	4						
75	GB93	SPRING WASHER M6	4						
76	GB97.1	WASHER M6	4						
77	QJY4040.5-03	NYLON SLIDER BLOCK	2						
78	GB819	SCREW M6X25	4						
79	QJY4040.5-06	HYDRAULIC FITTING 90° 3/8"NPT TO #6 JIS (9/16")	1						
80	QJY4030H.5.3	HYDRAULIC CYLINDER	1	QJY4030H.5.3	1	QJY4040.5.3	1	QJY4040.5.3	1
81	QJY245DS.9-06	PIN	2						
82	QJY4040.5-05	SHAFT	1						
83	QJY4040-30	HYDRAULIC BREATHER FITTING	1						
84	QJY4040-31	AIR HOSE	1						

## NOT SHOWN

85	QJY4040-31	HYDRAULIC CYLINDER SEAL KIT	1						
86	QJY4040-32	PLASTIC COVER HOSE	1						
87	QJY4040-33	AIR HOSE FITTING 90	4						
88	QJY4040-34	AIR HOSE FITTING T	3						
89	QJY4040-35	AIR HOSE FITTING STRAIGHT	1						
90	QJY4040-36	SAFETY LOCK COVERS	4						
91	QJY4040-37	ANCHOR BOLTS M16x150	16						

T9000-4ST		T7000-4NT		T7000-4N		T9000-4S			
Part #	Description	Part #	Description	Part #	Description	Part #	Description	Qty	
A	QJY4040H-02	LIFTING CABLE 3711	QJY4030H-01	LIFTING CABLE 3521	QJY4030-01	LIFTING CABLE 3020	QJY4040-03	LIFTING CABLE 3170	1
B	QJY4040H-03	LIFTING CABLE 5131	QJY4030H-02	LIFTING CABLE 4943	QJY4030-02	LIFTING CABLE 4442	QJY4040-02	LIFTING CABLE 4580	1
C	QJY4040H-01	LIFTING CABLE 8746	QJY4030H-03	LIFTING CABLE 8556	QJY4030-03	LIFTING CABLE 7188	QJY4040-04	LIFTING CABLE 7285	1
D	QJY4040H-04	LIFTING CABLE 10166	QJY4030H-04	LIFTING CABLE 9978	QJY4030-04	LIFTING CABLE 8610	QJY4040-01	LIFTING CABLE 8710	1

# 4-POST MAIN STRUCTURE

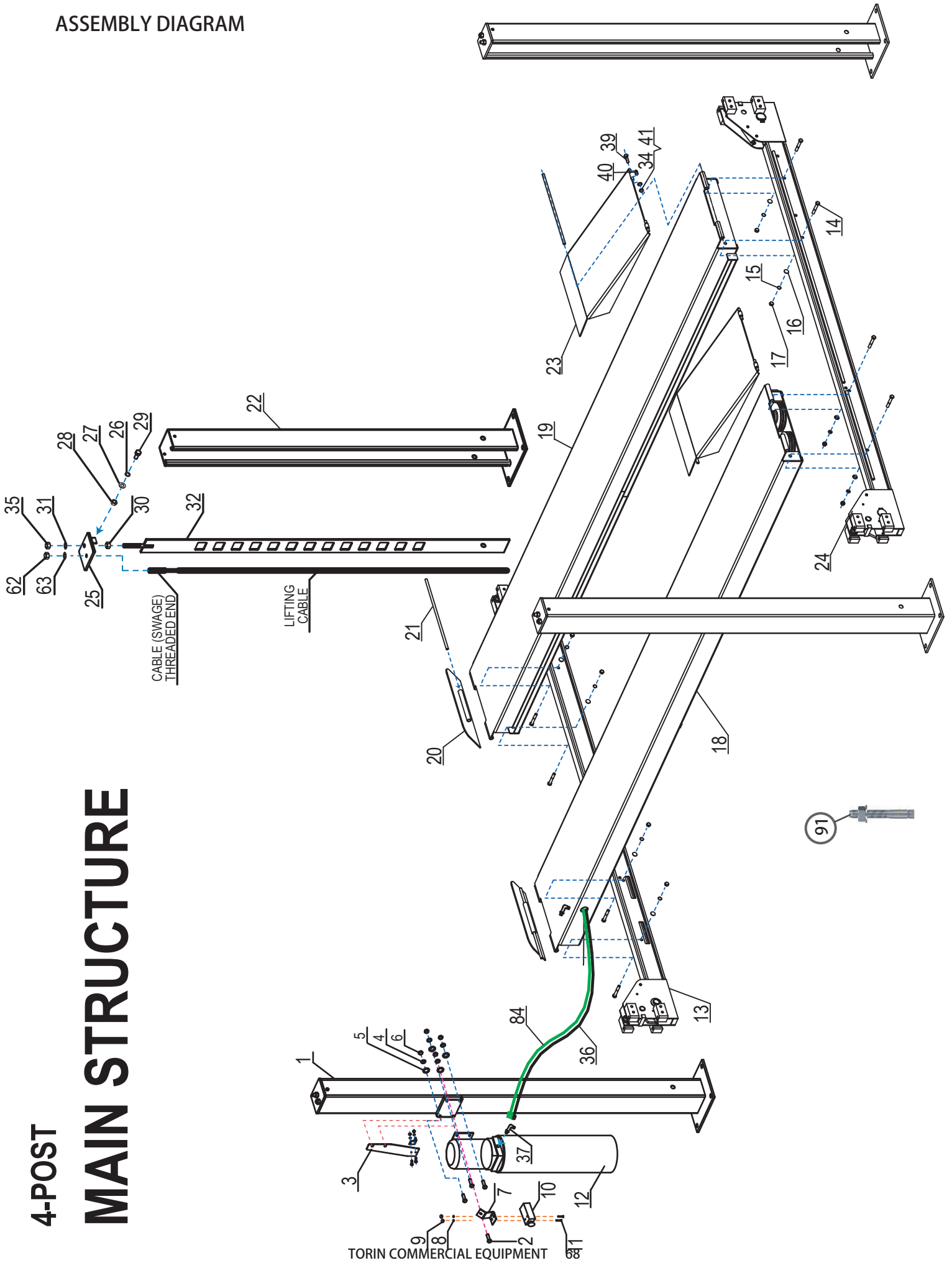

4-POST

# CROSSTUBE LIFTING BEAM

## COMPONENT ASSEMBLY

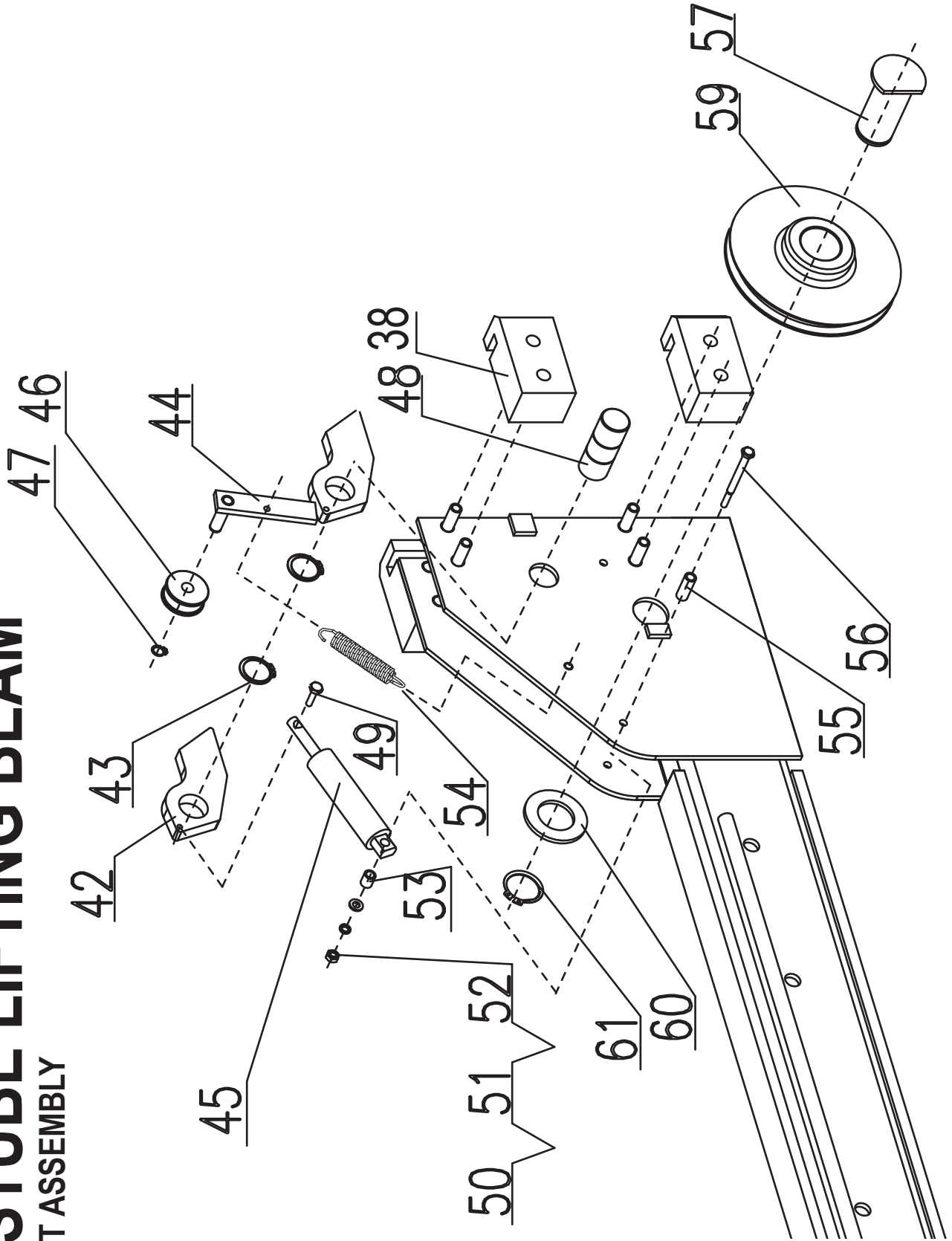

# 4-POST POWER-SIDE RUNWAY

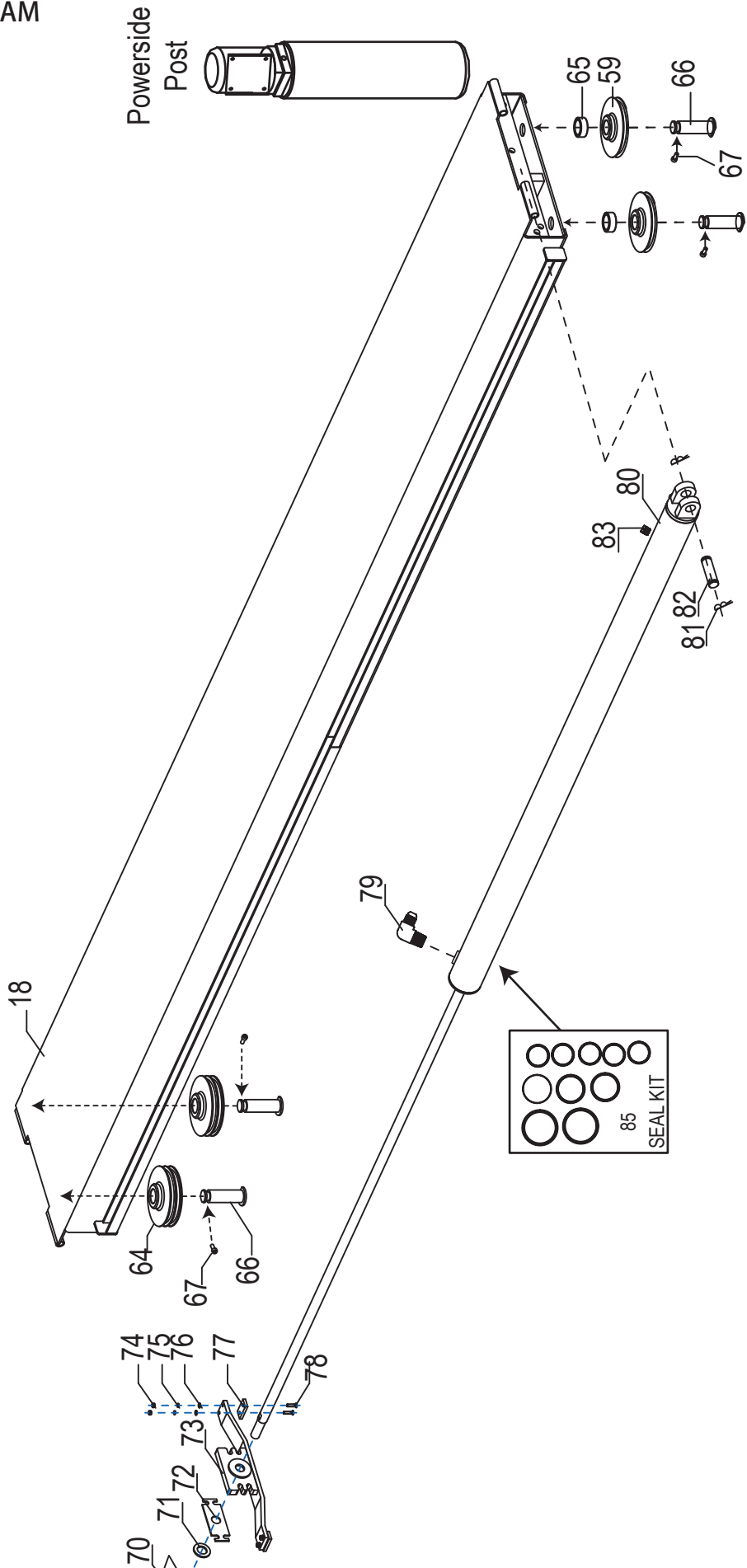

# 4-POST POWER-SIDE RUNWAY

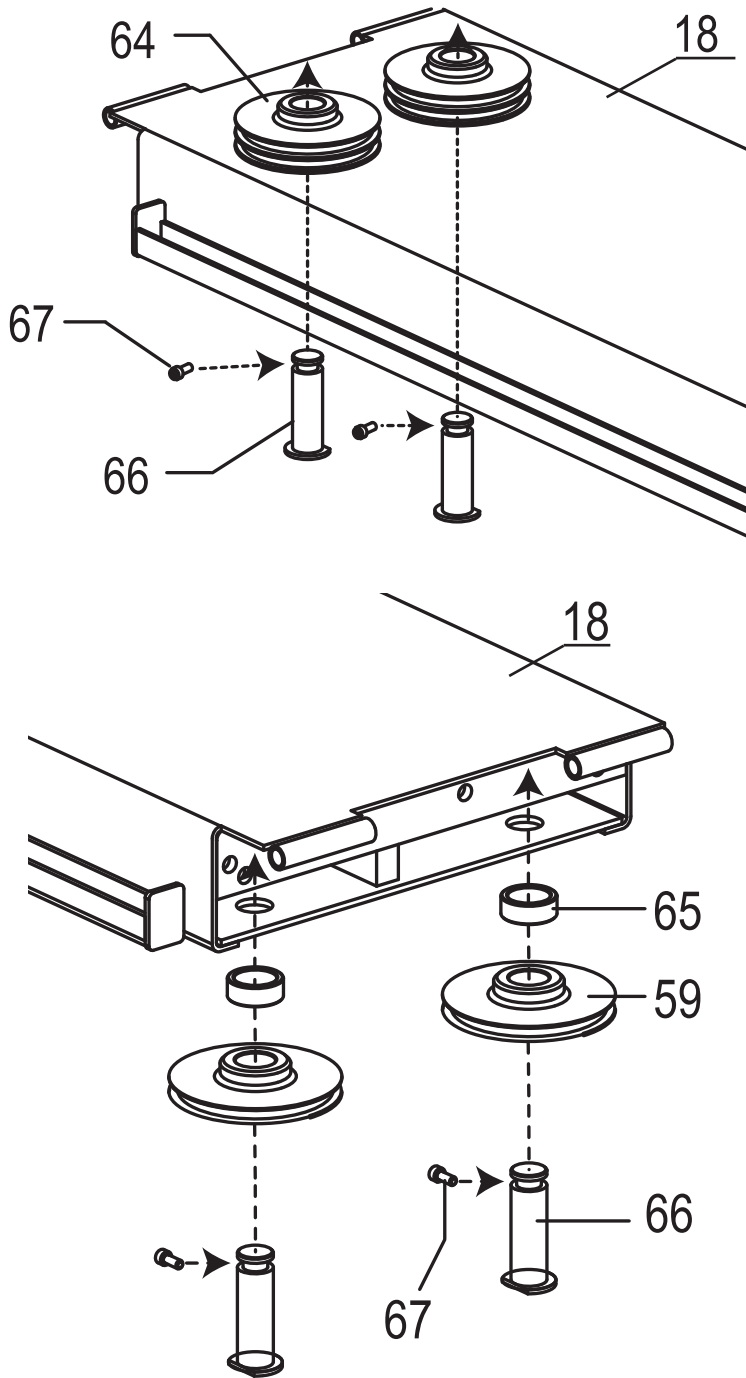

# 4-POST NON-POWER POST

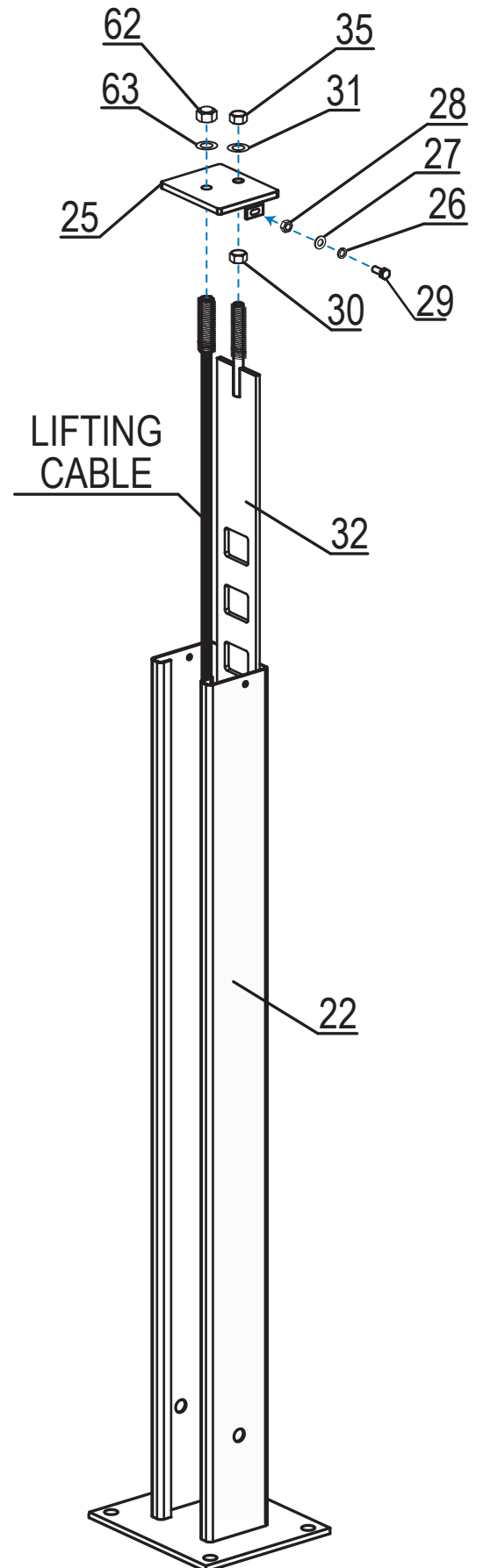

# POWER-SIDE POST

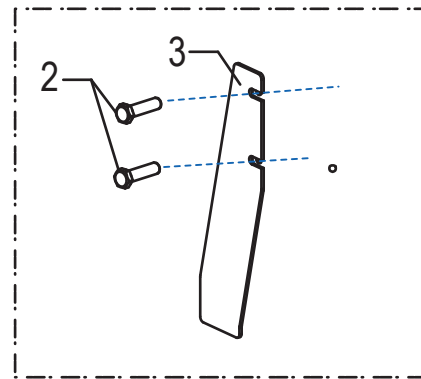
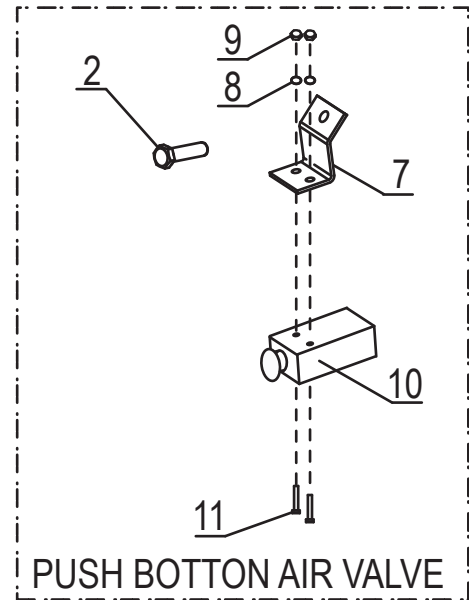
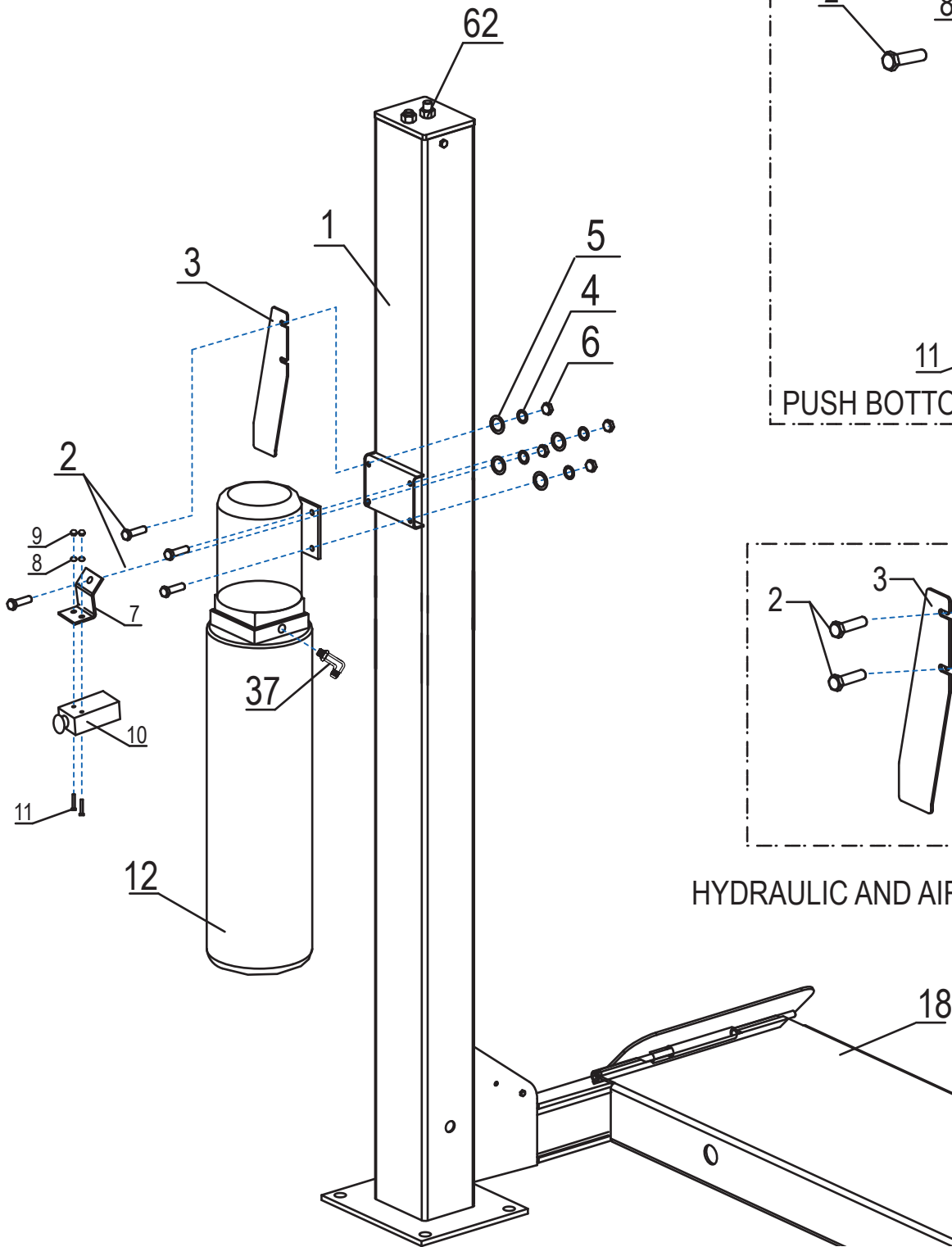

# 4-POST LIFTING CABLES ROUTING

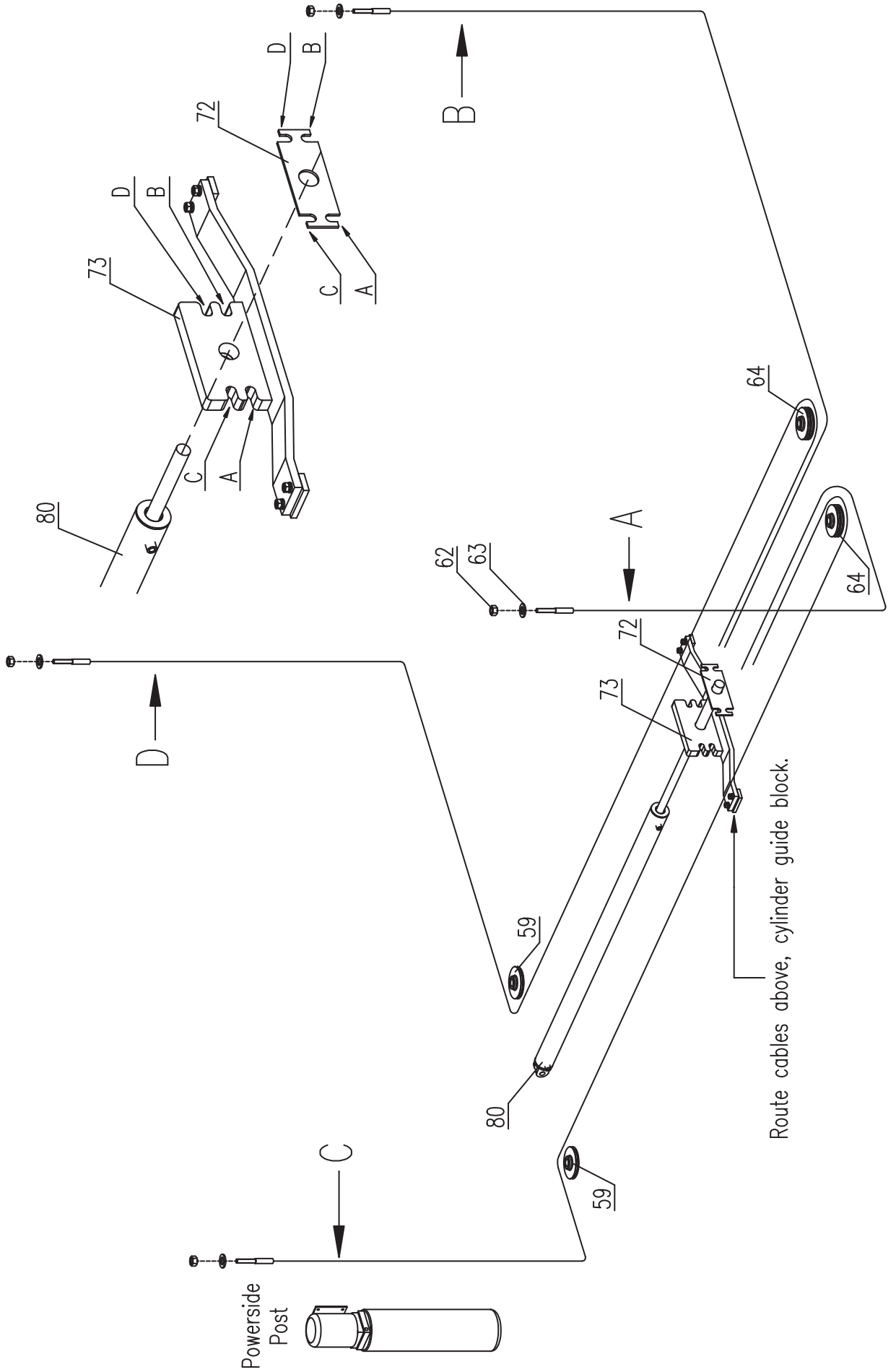





## **WARRANTY NOTICE**

This product is covered under a 1-year limited warranty when used as recommended. Only those items listed with a Part # are available for purchase. For assistance with the operation or the availability of replacement parts, contact our Parts and Warranty Department at 1-888-44-TORIN (1-888-448-6746). Please have available a copy of your receipt, the model number of the product, serial number, and specific details regarding your question.

Not all equipment components are available for replacement; illustrations provided are a convenient reference of location and position in the assembly sequence.

**ANY PRODUCT THAT IS NOT REGISTERED WITH WILL AUTOMATICALLY DEFAULT TO PRODUCT MANUFACTURED DATE FOR WARRANTY START DATE. CUSTOMER THAT DO NOT REGISTER A PRODUCT MUST PROVIDE PROOF OF PURCHASE AT THE TIME OF WARRANTY CALL.**

For online warranty registration please visit: [www.torin-usa.com](http://www.torin-usa.com)

**The manufacturer reserves the rights to make design changes and or improvements to product lines and manuals without notice.**

## **WARRANTY INFORMATION**

We want to know If you have any concerns with our products. If so, please call toll-free for Immediate assistance. For additional web customer support help inquiries visit the Customer Service section at [WWW.TORIN-USA.COM](http://WWW.TORIN-USA.COM)

## TORIN ONE YEAR LIMITED WARRANTY

Torin Inc.® has been producing quality automotive repair and maintenance products since 1968. All products sold are felt to be of the highest quality and are covered by the following warranty:

With proof of purchase for a period of ONE year from the date of that purchase, the manufacturer will repair or replace, at its discretion, without charge, any of its products or parts thereof which fail due to a defect in material or workmanship. This warranty does not cover damage or defects caused by improper use, careless use or abuse of the equipment. This warranty does not cover parts normally considered to wear out or be consumed in the normal operation of the equipment. Except where such limitations and exclusions are specifically prohibited by applicable law, (1) the CONSUMERS SOLE AND EXCLUSIVE REMEDY SHALL BE THE REPAIR OR REPLACEMENT OF DEFECTIVE PRODUCTS AS DESCRIBED ABOVE, and (2) THE MANUFACTURER SHALL NOT BE LIABLE FOR ANY CONSEQUENTIAL OR INCIDENTAL DAMAGE OR LOSS WHATSOEVER, and (3) THE DURATION OF ANY AND ALL EXPRESSED AND IMPLIED WARRANTIES, INCLUDING, WITHOUT LIMITATION, ANY WARRANTIES OF MERCHANTABILITY AND FITNESS FOR A PARTICULAR PURPOSE, IS LIMITED TO A PERIOD OF TWO YEARS FROM DATE OF PURCHASE. Product alteration in any manner by anyone other than us, with the sole exception of alterations made pursuant to product instructions and in a workman like manner. You acknowledge and agree that any use of the product for any purpose other than the specified use(s) stated in the product instructions is at Your own risk.

Always check for damaged or worn out parts before using any product. Broken parts will affect the equipment operation. Replace or repair damaged or worn parts immediately. Do not modify the product in any way. Unauthorized modification may impair the function and/or safety and could affect the life of the equipment. There are specific applications for which products are designed and tested during production. Manufacturer provided warranted items are not authorized to be repaired by anyone other than the manufacturer or manufacturer approved repair person. Distributer does not have authorization to amend these statements. You acknowledge and agree that any modification of the product for any purpose other than manufacturer completed repairs is at your own risk. Before using this product, read the owner's manual completely and familiarize yourself thoroughly with the product and the hazards associated with its improper use.

**IMPORTANT: BEFORE FIRST USE** on any Lift verify that a daily inspection has been completed and that all components are in the proper working order.

This limited warranty gives you specific legal rights, and you also may have other rights, which vary from state to state. Some states do not allow limitations or exclusions on implied warranties or incidental or consequential damages, so the above limitations may not apply to You. This limited warranty is governed by the laws of the State of California, without regard to rules pertaining to conflicts of law. The state courts located in San Bernardino County, California shall have exclusive jurisdiction for any disputes relating to this warranty.

Manufacturer reserves the rights to make design changes and or improvements to this product line and manual without notice. We at Torin have taken every effort to ensure complete and accurate instructions have been included in this manual. However, possible product updates, revisions and or changes may have occurred since this printing. Torin Inc. reserves the right to change specifications without incurring any obligation for equipment previously or subsequently sold. Not responsible for typographical errors.

For any warranty support or if your Torin® equipment is not functioning properly contact Torin® Customer Service directly by telephone at 1-888-44-TORIN (1-888-448-6746) 8:00am – 5:00pm Pacific Time, Monday – Friday  
Alternately Customer Service can be reached through [www.TORIN-USA.com](http://www.TORIN-USA.com) or via email at [info@torin-usa.com](mailto:info@torin-usa.com).

Not all equipment components are available for replacement, but are illustrated as a convenient reference of location and position in the assembly sequence. Contact Customer Service for equivalent component. When you contact us, please have your Product's Model number, Serial Number and Description ready so that we may help you efficiently. This information can be found on a sticker on the product.

# TORIN INC. INSTALLATION AGREEMENT

## TORIN Pre-Installation Agreement

I, (the undersigned) acting as the installer assume responsibility for any permits required for city, state or county mandated, related to the installation and/or operation of this equipment. I assume responsibility for the concrete floor and condition thereof, now or later, where the purchased equipment model(s) are installed. I will assume all liability for losses, damages (including loss of use), expenses, demands, claims, and judgments in connection with or arising out of any personal injury or alleged damage to property, sustained or alleged to have been sustained in connection with, or to have arisen out of the condition and/or drilling of the concrete near or adjacent to the equipment model(s) purchased. If anyone offers assistance of any kind during the installation of the purchased equipment model(s) I will not hold the manufacturer and installation company responsible for any liability for losses, damages, expenses, claims, and judgments in connection with or arising out of any personal injury or alleged damage to property, sustained or alleged to have been sustained in connection with the installation of the purchased equipment model(s).

I understand that the lifts purchased are supplied with concrete fasteners meeting the criteria of the ICC-ES compliance, and that I will be responsible for all charges related to any special regional structural and/or seismic anchoring requirements specified by any other agencies and/or codes such as the Uniform Building Code (UBC) and/or International Building Code (IBC). *This addendum also covers lifts installed in other distributor markets that included the European Unions, Mexico, South America, Africa, Russia, and Australia under CE Ref. no. EN1493-2010 European Standard for Vehicle Lifts and North American Standards.*

## Post-Installation Agreement

I, (the undersigned) confirm that the purchased equipment installation procedure(s) were completed. I understand that I will be responsible for maintaining this equipment as outlined in the accompanied Installation and Operation Manual and Safety Requirements for Operation, Inspection and Maintenance. I understand that personal injury and/or damage to property can occur if the purchased equipment model(s) are not maintained or used improperly and take full responsibility for training my employees on proper use and maintenance of this equipment. I will not hold the manufacturer and installation company responsible for any liability for losses, damages (including loss of use), expenses, demands, claims, and judgments in connection with or related to improper use, improper training, or lack of required maintenance. I understand that the warranty does not cover replacement of parts worn or damaged due to normal use or lack of required maintenance.

## Miscellaneous Terms

- **No Other Agreement.** Except as otherwise mutually agreed in writing, this Installation Agreement and the incorporated Purchase Order are the complete agreement of the parties and supersede all other agreements or understandings, written or oral.
- **Indemnification:** Our liability for damage caused by our negligence or that of our subcontractors/agents shall be limited to the applicable policy limits of our liability insurance.
- **Terms of Payment.** In addition, the terms stated above, you agree to pay all costs of collection, whether or not we enforce a mechanic's lien or otherwise file suit, including without limitation all attorney's fees, filing fees, and court costs as they are billed by us. Such unpaid additional costs shall be subject to interest at 1.5% per month until paid.
- **Limitation of Damages.** We will not be liable for any delay in performing any work or providing any materials hereunder, or any cessation of or interruption of services, including but not limited to those arising out of fire, flood, explosion, war, strike, power blackout, nature, civil or military authority, inability to obtain labor or materials or reasonable substitutes therefore, terrorist threats or activities or any other cause beyond our reasonable control or acts of God.
- **Limitation of action.** Except for claims for overdue balances, any other lawsuit hereunder shall be brought within one (1) year of completion of our installation notwithstanding any other statute of limitation that would otherwise apply.
- **Choice of Law.** This Agreement shall be governed by the laws of the State of California, without regard to rules pertaining to conflicts of law. The state courts located in San Bernardino County, California shall have exclusive jurisdiction for any disputes relating to this warranty.
- **Successors and assigns.** Your rights hereunder may not be assigned to a third party.
- **Venue.** The parties agree that the state courts located in San Bernardino County, California, shall be the only proper forum and court of competent jurisdiction for any dispute arising hereunder.
- **Authorship.** The parties agree that this Agreement has been negotiated and drafted by them equally and that neither party shall have the benefit of an adverse inference being drawn against the other party.
- **Severability.** If any provision herein should, for any reason, be construed by a court of competent jurisdiction to be invalid or unenforceable, all other provisions shall remain in full force and effect and be construed so as to make this Agreement enforceable to the maximum extent allowed by law.
- **Counterparts; Facsimile.** This Amendment may be executed in counterparts, each of which when so executed and delivered shall be taken together to be an original; but such counterparts shall together constitute one and the same document. Facsimiles shall have the force of an original.

LIMITATION OF REMEDIES AND DISCLAIMER OF WARRANTIES. WE WILL NOT BE LIABLE IN ANY CASE FOR ANY LOSS OF USE, LOST PROFITS, SPECIAL, INCIDENTAL, CONSEQUENTIAL, INDIRECT, OR PUNITIVE DAMAGES. IN NO EVENT, SHALL OUR LIABILITY EXCEED REIMBURSEMENT OF ANY MONIES PAID BY YOU UNDER THIS AGREEMENT AND THIS SHALL BE YOUR EXCLUSIVE AND SOLE REMEDY FOR ANY CLAIM HEREUNDER. THE FOREGOING LIMITATION SHALL NOT APPLY TO CLAIMS FOR PERSONAL INJURY. THE LIMITATIONS, EXCLUSIONS AND DISCLAIMERS IN THIS SECTION AND ELSEWHERE IN THESE TERMS OF USE APPLY TO THE MAXIMUM EXTENT PERMITTED BY APPLICABLE LAW.

## TORIN INC. INSTALLATION AGREEMENT

Email Signed Installation Agreement to [info@torin-usa.com](mailto:info@torin-usa.com)

or

Mail Signed Installation Agreement to TORIN INC. 4355 E. Brickell St. Ontario, CA 91761 USA

### Pre-Installation Agreement Signatures Required:

Customer Name:		Date of Installation:
Company Name (if applicable):		
Street Address:		
City:	State:	Zip:
Phone:	Fax:	
Customer Signature:	Print Name:	Date:
Product Model Number:	Product Serial Number:	Product Manufactured Date:

### Post-Installation Agreement Signatures Required:

Installer Company Name:		
Street Address:		
City:	State:	Zip:
Phone:	Phone (Other):	
Customer Signature:	Print Name:	Date:
Installer Signature:	Print Name:	Date:

✓ *Check boxes to verify work has been completed*

<input type="checkbox"/>	Base and columns properly shimmed and stable
<input type="checkbox"/>	Anchor bolts tightened to 150 ft-lbs torque
<input type="checkbox"/>	All screws, bolts, and pins secured
<input type="checkbox"/>	Electric power supply confirmed
<input type="checkbox"/>	Cables and chains adjusted properly
<input type="checkbox"/>	Safety locks functioning properly
<input type="checkbox"/>	Checked for hydraulic leaks
<input type="checkbox"/>	Oil level is full

<input type="checkbox"/>	Lubrication of critical components complete
<input type="checkbox"/>	Lift adapters and accessories functioning properly
<input type="checkbox"/>	No overhead obstructions
<input type="checkbox"/>	Surrounding area and lift clean in appearance
<input type="checkbox"/>	Proper operation, maintenance and safety explained
<input type="checkbox"/>	Operation and safety manual(s) left at site
<input type="checkbox"/>	Runways properly attached and secured (if applicable)
<input type="checkbox"/>	Runways level and plumb (if applicable)



Contact Torin® Customer Service directly by telephone at:  
1-888-44-TORIN (1-888-448-6746)  
8:00am – 5:00pm Pacific Time, Monday – Friday

Comuníquese con el Servicio de Atención al Cliente de Torin® directamente por teléfono al:  
1-888-44-TORIN (1-888-448-6746)  
De lunes a viernes de 8:00 a. m. a 5 p. m. hora del Pacífico

Communiquez directement avec le Service à la clientèle Torin® au:  
1-888-44-TORIN (1-888-448-6746)  
De 8 heures à 17 heures, heure du Pacifique, du lundi au vendredi

**Torin Inc.**  
**4355 E. Brickell Street Ontario, CA USA**  
**<https://torinjacks.com/>**  
**E-Mail: [torinbigredusa@gmail.com](mailto:torinbigredusa@gmail.com)**  
**Made in China - Hecho en China - Fabriqué en Chine**

