



AUTOMATIC TYRE CHANGER

Installation

Operation

Maintenance

JUNY-BTJ3



Manual





Symbol and code printed

In the manual, the following symbols and codes is for the convenience of reading.

	need careful operation
	prohibited
	may cause dangerous to the operator
Bold	Important info

	Warning: Before lifting and any adjustment, carefully read the Chapter 7 "Installation" among which it is the operation suitable for the best lift.
--	--

CONTENT

Chapter 1 Introduction.....	1
Chapter 2 General information.....	1
Chapter 3 Transportation, Unpacking and Storage.....	3
Chapter 4 Installation.....	4
Chapter 5 Operation.....	9
Chapter 6 Inflation.....	12
Chapter 7 install the assist arm and operation.....	13
Chapter 8 Maintenance.....	13
Chapter 9 trouble shooting.....	15
Chapter 10 Electrical and pneumatic scheme.....	15

Chapter 1 Introduction

1.1 Introduction

Thanks for you purchase this product from the series products of tire changers. This product is based on the best quality principal. Following the simple instruction in this manual can ensure the correct operation and prolong the life of the machine. Read the manual thoroughly and ensure that you have understood it.

1.2 Tire changer identification data

The complete description of the model and series number can make our technical department provide the service more easily. And it is also convenient for the shipment of the spare parts. We add the data of the tire changer in the following column. If there is any difference between the data in the manual and the data on the nameplate, we should consider the nameplate attached on the machine to be correct.

<p>Model: voltage: 110V Ampere: kilowatt: 1.1kW phase: Single phase Hertz: 60Hz pneumatic source: 8-10bar (115-145PSI)</p>

1.3 Keep of the manual

To correctly use this manual, we suggest as follows:
Keep the manual easy to pick up
Keep the manual in the condition moisture-resistant
Properly use this manual and do not damage it
The operator of the machine must familiar with the instruction and program in the manual

This manual is the integrated part of the product. It should be provided to the new owner when the machine is resold.

	<p>The components and parts on the picture may be different from the actual ones.</p>
---	---

1.4 General safety precaution

	<p>The tire changer should be operated by the professional personnel specially authorized.</p>
---	--

Chapter 2 General information

2.1 Purpose

This automatic tire changer is designed and manufactured to mount/demount the rim.

We hereby state that the manufacturer will not bear the responsibility to the damage arising from the use not stated in the manual or improper, incorrect and unreasonable.

2.2 Instruction to the part of the machine

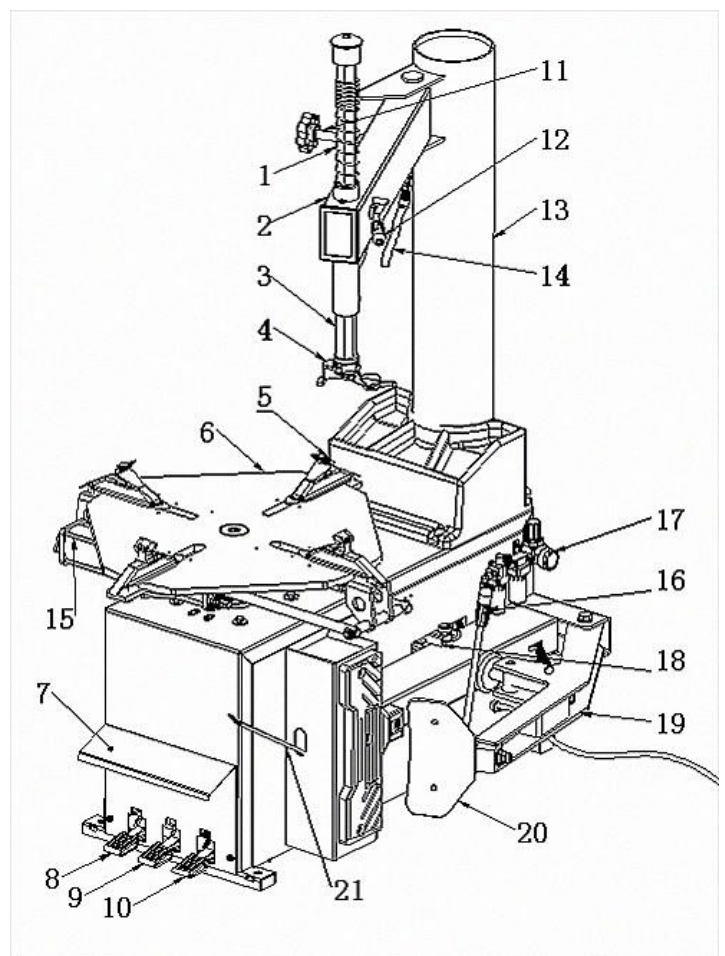

Fig2-1

- | | |
|--------------------------|-----------------------------|
| 1. Vertical shaft spring | 2. Rocker arm |
| 3. Hex shaft | 4. Tool head |
| 5. Clamping jaw | 6. Turntable |
| 7. Front panel | 8. Turntable rotation pedal |
| 9. Clamping pedal | 10. bead breaker pedal |
| 11. Limit handle | 12. Lock handle |

- 13. Column with air tank
- 14. Inflation gun
- 15. Clamping cylinder
- 16. Blade handle
- 17. Air regulator
- 18. Bead breaker cylinder
- 19. Bead breaker arm
- 20. Blade
- 21. Crowbar
- 22. Rubber support

2.3 Dangerous warning stick



Keep the hands away from tire when operating

Carefully read the manual before using

Wear the protection device when operating



Electrical shock !



Do not position any part of your body under the tool head.



When bead breaking, the blade will move leftwards very fast and the operator should not stand between the blade and tire.

When blast inflation, you must secure the wheel is firmly fixed

When operating, you should not wear long hair, loose suit and jewelry



When operating, do not reach your hand under the fallen parts



Note: When press the tire, if the clamping cylinder is open, it will scratch the hand of the operator. Keep in mind that the hand should not contact the side wall of the tire.



When clamping the rim, do not place the hand and the other part of the body in between the clamping jaw and rim.



Do not stand behind the column avoiding injure the personnel when the column swing.

SAFETY LABEL POSITION DIAGRAM

Pay attention to keep the safety labels complete. When it is not clear of missing, you should change the new label.

You should let the operators see the safety labels clearly and understand the meaning of the label.

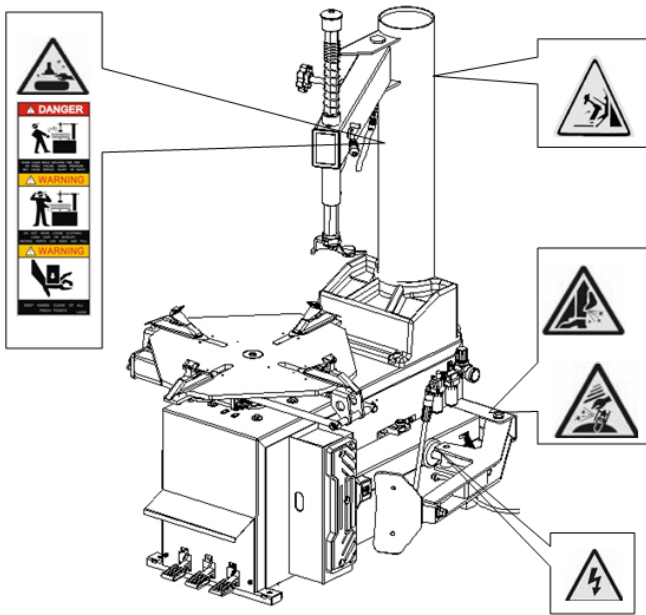

2.4 Technical specification:

Basic size of the equipment (without the optional accessory such as helper)

Technical parameter

Work pressure: 8-10bar (117 - 145 psi)

Motor parameter:

110V 60hz single phase (standard configuration)

Turntable rotation speed: 6rpm

Noise: <70dB (A)

Application

Model	JUNY-BTJ3
Max wheel diameter	39inch / 1000mm
Max wheel width	3-12" / 76-304mm
Rim diameter (inside clamping)	12-24" / 305-609mm
Rim diameter (outside clamping)	10-22" / 254-558mm
Packing size	980 x 770 x 870mm 39" x 31" x 35"
N.W / G.W	173kg / 199kg 381lbs / 438 lbs

(It is designed to change the motorcycle tire adopting movable seat and enlarge the clamping size)

Environment requirement

Ambient temperature-5°C ~ 40°C

RH30% ~ 95%

Max.sea level 1000M

Without dust and the air easy to explode and flammable and corrosion air

Chapter 3 Transportation, Unpacking and Storage

3.1 Transportation

The transportation of the tire changer needs the original package and the location as indicated in the figure

The tire changer packed needs to be transported by the forklift with the proper load. Insert the fork into the position indicated in Fig 3.1.

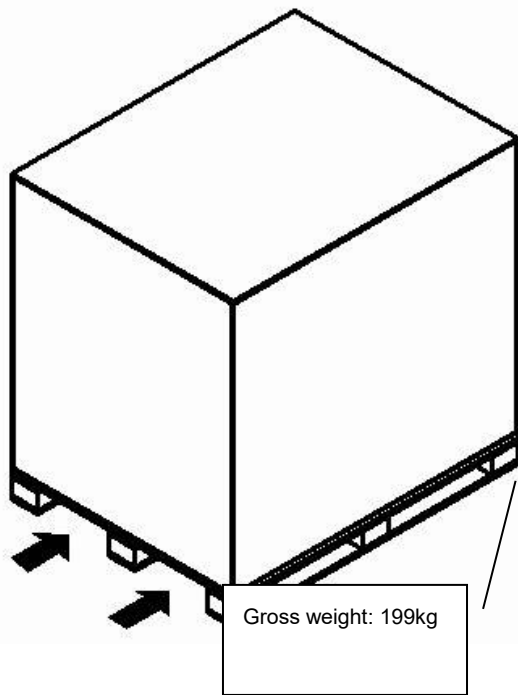

3.2 Unpacking

Remove the cardboard and nylon bag for protection
 Check if the equipment is intact and make sure there is not any part lost or damaged.



If question, do not use the machine and contact the retailer.

3.3 Storage

If you need long time of storage of the equipment, you should secure the electrical supply is switched off and lubricate the clamping jaw guide rail on the turntable to avoid the oxidization.

Chapter 4 Installation

4.1 Choice of the space



When you choose the installation site, you should make sure it is corresponding to the current safety regulation.

The tire changer must be connected with the power

supply and pneumatic source, therefore, we suggest to choose the installation site of the tire changer to the location near the power supply and pneumatic source to guarantee the correct operation of all the parts of the machine. If the machine is installed outdoors, the machine should be equipped with the



The tire changer with the motor should not be used in the environment with the potential of exploded.

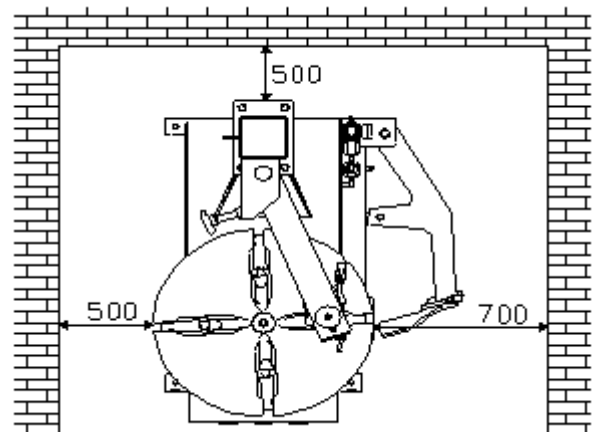

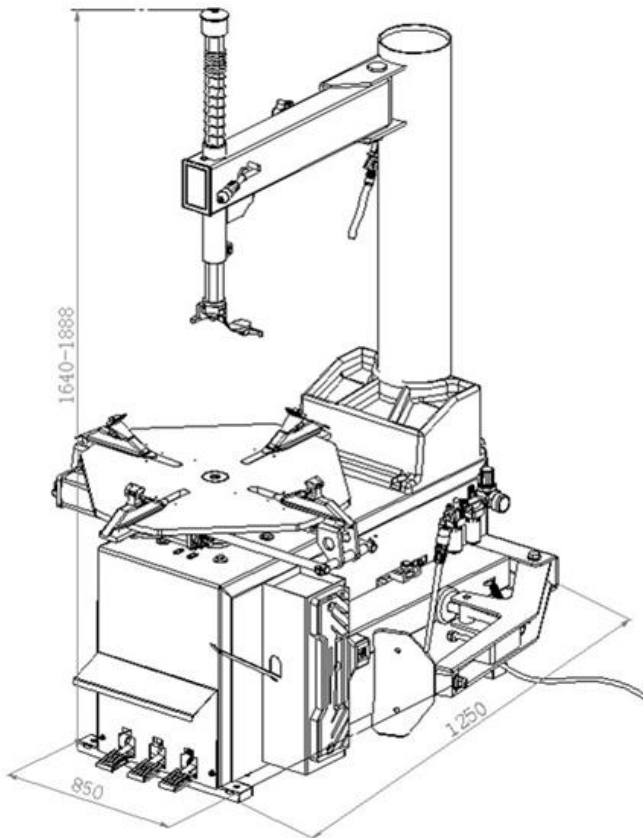

4.2 Parts assembly

4.2.1 Arm assembly

Carefully read the manual before installation, any modification to the parts without the permission of the manufacturer may cause the damage to the machine.

The personnel to execute commission must have some knowledge of electricity.

The operator must under the special trained and be authorized.

Carefully check the equipment list, if any question, contact the dealer or the manufacturer immediately. To secure the success of the installation and commission, you should prepare the following common tools:

Two wrenches (10") , one socket wrenches, one hexangular wrench, one tung and one screw driver,

one hammer and one multi-purpose meter

4.2.2 DEPACKAGE

4.2.3 According to the de-package instruction on the package box, to detach the box and remove the package material to check if the machine damage or not and if the spare parts completed.

4.2.4 Keep the package material far away from the working site and deal with it properly.

4.2.5 INSTALLATION

As shown in Fig 4-1, unpack the package box and take out the accessories (1) bead breaker arm (5) and column assembly (2) and fix the body as Fig4. Unscrew the hex screw (4) on the body and elastic washer and flat washer.

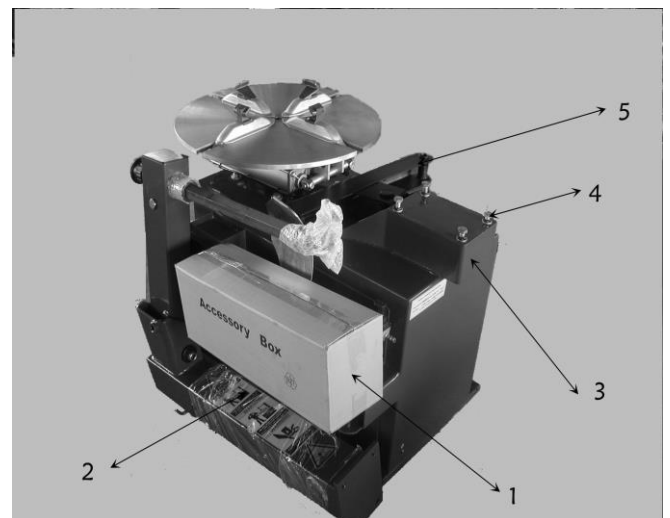

Fig 4-1

4.2.6 Position the column assembly on the body with the warning stick facing toward. Retighten the bolt, flat washer and elastic washer removed shown in Fig 4-1 evenly. The tighten torque is 70 N·M

(Fig 4-2) and use the torque wrench to fix.

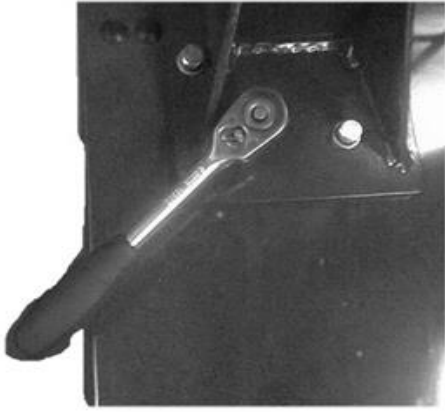

Fig 4-2

4.2.7 Use the hexagonal wrench to unscrew the screw (3) on the hexagonal shaft (3) to remove the vertical shaft cap (2). When remove the screw on the vertical shaft cap, you should lock the hexagonal shaft by the lock handle to keep it from falling down to damage the machine of cause the personnel accident !

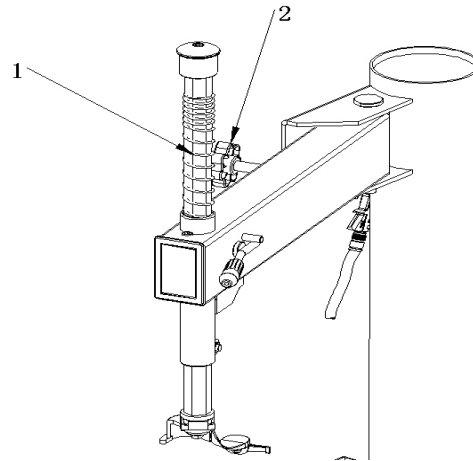

Fig 4-4

4.2.8 Unscrew the lock nut (1) at the front end of the bead breaker cylinder piston rod. Use the spring tongs to remove the retaining ring on the bead breaker arm pin shaft. Remove the pin shaft (3) and hang the spring (5) as shown in Fig 4-5.

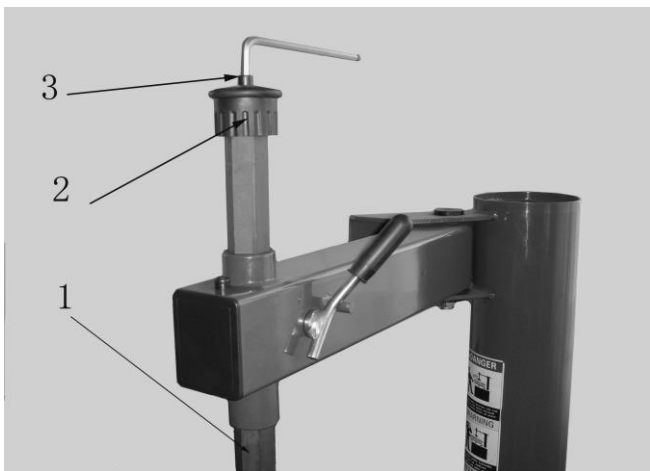

Fig 4-3

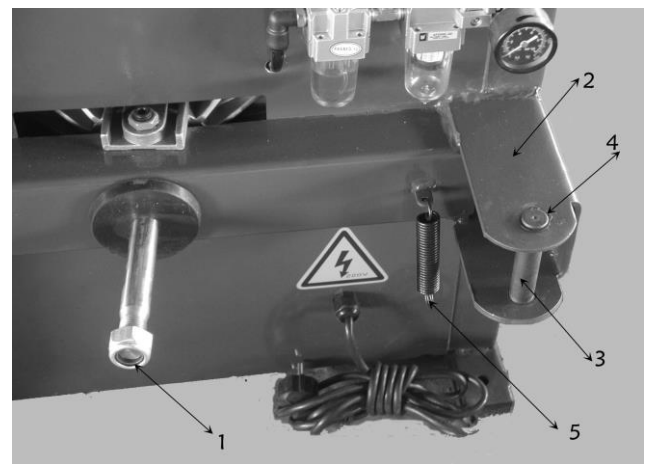

Fig 4-5

4.2.9 Insert the bead breaker arm (1) into the bead breaker bracket on the body and align the two holes and mount the bead breaker arm pin shaft (2) and also elastic retaining ring to positioning. Hang the spring (Fig 4-6-3) as shown in Fig 4-6.



Cover the vertical shaft spring (1) on the vertical shaft. Mount the screw detached from the vertical shaft cap and use the hand wheel to screw into the nut bushing of the rocker arm as shown in Fig 4-4.

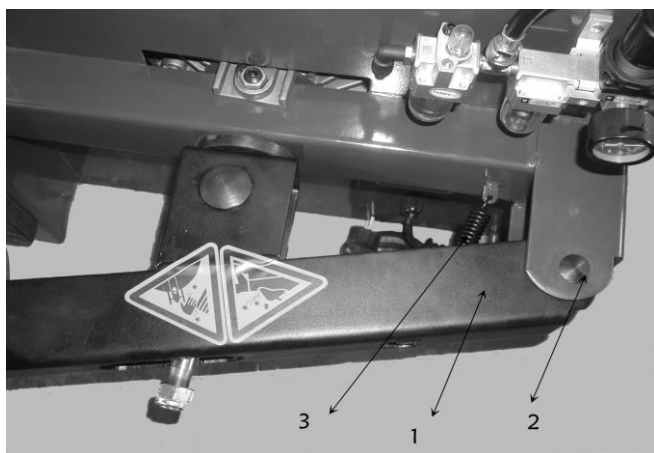

Fig 4-6

4.2.10 Insert the piston rod from the hole of the bead breaker slide bushing (Fig4-7-1). The plane of the slide bushing face outwards (Fig4-7). Screw the screws detached into the front end of the piston rod.

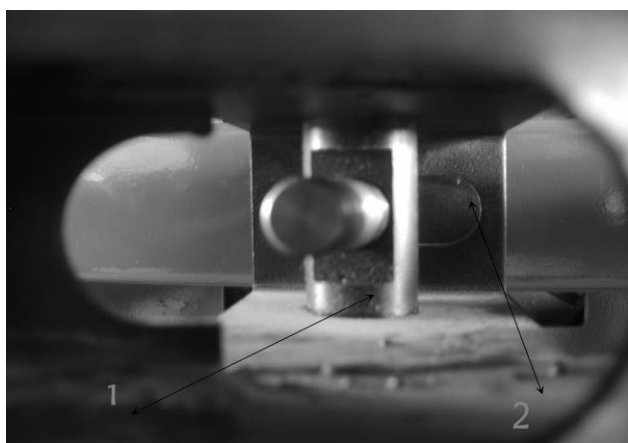

Fig 4-7

4.2.11 The distance from the sharp of the bead breaker blade to the wheel support is 30~40mm (Fig4-8).



Fig 4-8

4.2.12 Installation of air regulator

When out of factory, detach the air regulator and place into the accessory box. The customer should install at site. Take out the air regulator and screw 2 and remove the oil and dust and use the screw to fix it at the right side of the body. (Fig 4-9)

Note: When installation, you should cut off the air source!



Fig 4-9

4.2.13 connect the air hose, detach the union on the $\phi 8$ PU hose on the side of body. This union is for the purpose to keep the air hose from falling into the body. Insert the union in front the air regulator see Fig4-10/Fig4-11.



Fig 4-10



Fig 4-10

4.2.14 Connect the inflation gun or inflation gauge box:

Embed the inflation gun or inflation gauge box into the groove of the open nut on the air regulator (Fig4-11) . Tighten the open nut and connect the air route.

4.2.15 The air regulator has been calibrated well. If you want to change it, you can setup the pressure again: Lift up the pressure regulating button (1) , Turn clockwise, the pressure will increase and reduce if turn counterclockwise.



Fig4-11

4.2.15 The air regulator has been calibrated well. If you want to change it, you can setup the pressure again: Lift up the pressure regulating button (1) , Turn clockwise, the pressure will increase and reduce if turn

counterclockwise.

Oil feed regulation: Use the screw driver (2) to screw the screw. If clockwise, oil feeding will slow, if counterclockwise, oil feed fast.

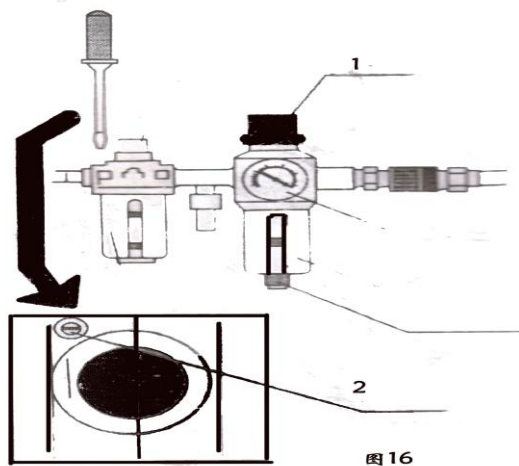

Fig4-12

4.2.16 The location to hang the pressure gauge

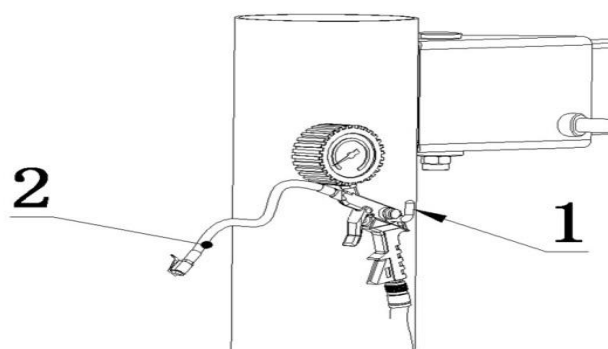

Fig4-13

When you do not use the inflation gun (Fig4-13-2) , you can hang the inflation gun at the hook. (Fig4-13-1)。

4.3 Commission

	<p>All the work related to the electrical must be undertaken by the professional personnel to secure the power supply to be correct and also the phase connect is correct. The improper electricity will damage the motor and without warranty</p>
--	--

Check if the characteristics of your system meet the requirements of the machine. If you have to change the voltage of the machine, please refer to the electrical scheme in Chapter9 to adjust the termination board.

Connect the inlet of the air regulator (Fig4-14 -17) through the machine with the compressed air system.

	<p>Connect the machine with the electrical system which is equipped with fuse. Perfect grounding should meet the local national standard. When necessary, equip with the electrical leakage protection to secure the safety running of the equipment. If the tire changer not equipped with power plug, the customer should equip one pc. The min. current of the plug should be 16A , meanwhile meeting the relative regulation to the voltage of the machine.</p>
---	---

4.4 Operation test

Press down the pedal (Fig4-14-10), turntable will rotate clockwise. Lift up the pedal. Turntable will rotate counter clockwise.

	<p>If the turntable does not rotate as per the methods described above, change the 2 wires on the 3-phase connect column.</p>
---	---

Press down the pedal 8, 4 pcs of clamping jaw will open . Once again press down the pedal, the clamping jaw will close;

Press down the pedal 9, bead breaker blade will enter the work condition. Once again blade will go to the original position;

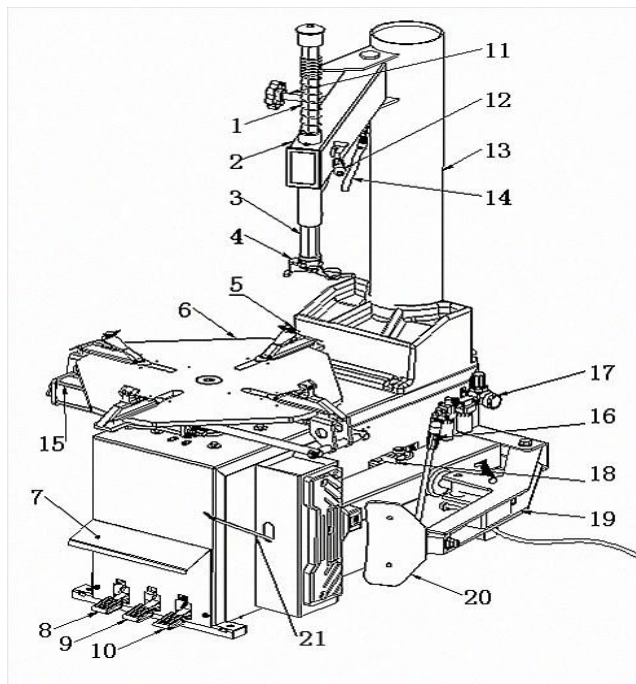



Fig4-14

Chapter 5 Operation

	<p>After read and understand the manual and its warning, you can use the machine.</p> <p>Before operation, completely deflate the air in the tire and detach all the weights on the tire.</p>
---	---

The operation of the tire is composed of

- a) bead breaking b) demounting tire c) mounting tire

	<p>We suggest equipping the pressure regulating device.</p>
---	---

5.1 Bead breaking

	<p>Before operation, you should make sure all the weights should be detached from the tire and remove the core, checking the deflation of the tire.</p>
---	---

Position the tire in between the bead breaker blade and wheel support(Fig5-1), then step down the bead breaker pedal (Fig4-14-10) to separate the bead and the rim. Repeat the above operation at the other position of the tire to make the beads of the both side completely detached from the rim. Place the wheel on the turntable and step down the clamping pedal (4-14-9) to firmly clamp the rim (choose the inwards clamping or outward clamping in accordance with the rim) . Prepare for demounting tire.

	<p>You should be very carefully when breaking bead. When bead breaking pedal drive the bead breaking arm ship quickly and powerful, the bead breaker arm will be danger to or crush all the things in its stroke area.</p>
---	--

Check if the tire is deflated, if not, completely deflate the air in the tire.

Completely close the turntable clamping jaws.

	<p>When bead breaking, if the clamping jaw at the open position, it will be very dangerous to the hand of the operator.</p>
---	---

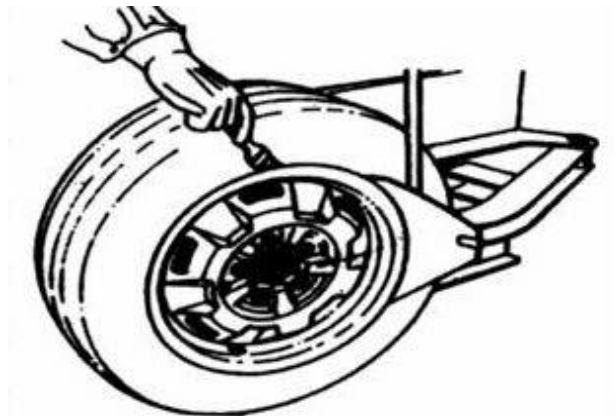





Fig 5-1

5.2Demount tire

2Demount tire

	<p>Spread the grease on the bead. Not use of grease will cause the damage to the bead.</p>
	<p>During locking the rim, never position your hand under the tire. The correct position to fix is the tire is just at the center of the turntable.</p>
	<p>Make sure the rim is firmly fixed on the clamping jaw.</p>

Position the hexangular shaft (Fig4-14-4) at the work position, making the tool head firmly contact the upper edge of the rim. Use the hand wheel (Fig4-14-11) to lean against the rocker arm. Then use the lock handle (Fig4-14-12) to lock and the tool head will shift automatically and leave some clearance (Fig5-2)

The angle of the tool head has been setup and calibrated before ex-factory in accordance with the standard rim (13"). If you handle the rim of extra large or small, reposition

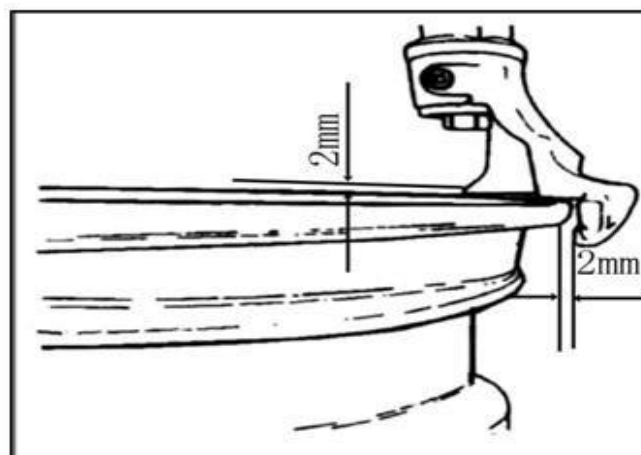



Fig5-2

	<p>To avoid damaging the tube, you should position the valve at the right side of the tool head, the distance should be 10cm (Fig5-3)</p>
---	---

	<p>Necklace, bracelet, loosen clothes or the movable foreign objects near will damage the operator.</p>
---	---

Use the crowbar to position the bead to the protrude of the tool head (Fig5-4), Step down the turntable pedal (Fig4-14-8) the turntable will rotate clockwise until upper bead is completely detached.

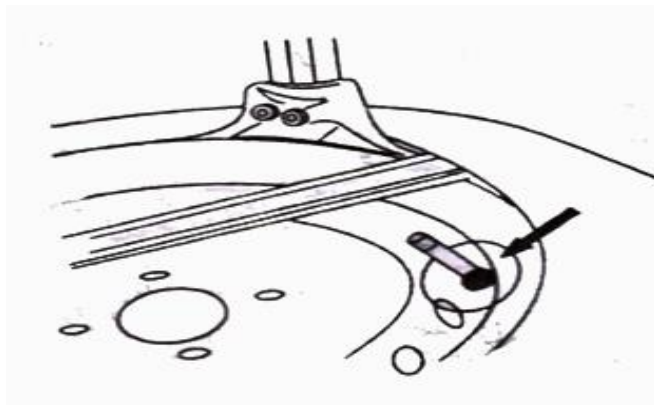

Fig 5-3

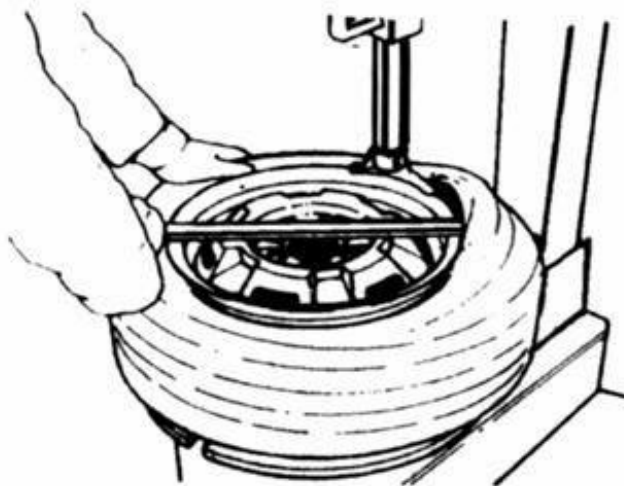



Fig 5-4

	<p>If demounting tire is jammed, stop the running at once. Lift up the pedal and rotate the turntable counterclockwise to remove the jamming!</p>
---	---

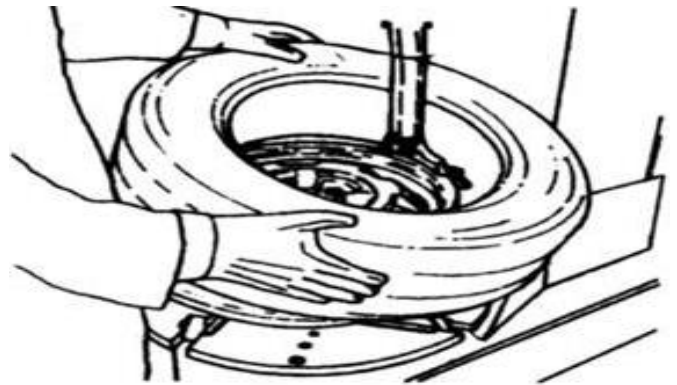





Fig 5- 5



5.3Mount tire

	<p>The most important is to check the tire and rim to avoid the exploration in the process of inflation. Before mounting tire, you should make sure that:</p> <p>The thread and tire not damaged, if there is any damage, do not mount the tire.</p> <p>Not find any dent and pay attention there is not any scratch onside the Aluminum alloy rim. It is very dangerous especially when inflation.</p>
---	---

	<p>In the process of clamping the rim, do not place your hand in between the rim and clamping jaw to avoid the damage to the person!</p>
---	--

	<p>When lock the rim, not put your hand under the tire. The correct operation is to make the tire in the center of the turntable.</p>
---	---

Lean the tire against the rim (left higher and right lower), Press down the hexangular shaft, making the tool head firmly contacted with the rim. Left rear bead over the tool head tail and right front bead under the front of the tool head (Fig5-5) Use your hand to press the bead into the groove of the rim. Step down the pedal (Fig4-14-8) making the turntable rotate clockwise. Continue this operation until the tire is completely inserted into the rim.

	<p>To avoid the industrial accident, the hand and the other part of your body should be kept away from the tool arm when the turntable is rotating.</p>
	<p>If there is tube, mount it inside the tire. Mount the core and upper bead as per the above step.</p>
	<p>When demount/mount the tire, the turntable should rotate clockwise. The counterclockwise is only used when the incorrect operation.</p>

Chapter 6 Inflation

	<p>When inflating, you should be very carefully. Strictly follow the following instruction. For the design and manufacture of the tire changer not protect the persons nearby when the tire suddenly exploded.</p>
---	--

	<p>Tire exploration may cause the serious damage to the operator and even death. Carefully check is the size of the rim is same to the size of the tire. Before inflation, you should check is there is any fault or wear on the tire. Check the air pressure after inflating. The max. Inflation pressure set up is 3.5bar=51psi. Do not exceed the pressure value the manufacturer suggest and keep your hands and body far from the tire.</p>
---	--

6.1 Common inflation procedure:

Our tire changer is equipped with the inflation gauge and the inflation procedure is as following.

- ① connect the inflation gauge with the tire valve
- ② Check if the size of tire is corresponding with the size of the rim.
- ③ Check if the bead is fully lubricated. If necessary, continue lubrication
- ④ Inflation. Check the pressure of the pressure gauge
- ⑤ Continue inflation. Check the air pressure while inflating.

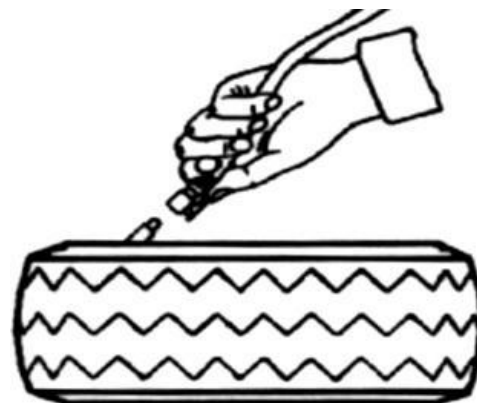

	<p>Danger of exploration ! It should not exceed 3.5bar (51psi) when</p>
--	---



inflating. If require relative high pressure, detach the tire from the turntable and place into the inflation cage. Never exceed the pressure the manufacturer suggests. Hand and part of body should be at the rear side of the tire being inflated. Only the professional personnel trained, the others should not operate the machine or at the zone near the tire changer.

Chapter 7 Installation & operation of the assist arm (optional device)

PL330 left assistant can be equipped on the tire changer which can handle the tire with the diameter of 20" to help complete the demounting on the stiff and low profile tire. We can use it to handle the work which if difficult and impossible to do only by the operators.

7.1 install the left assist arm

Before installation, the power and air source must be cut off!

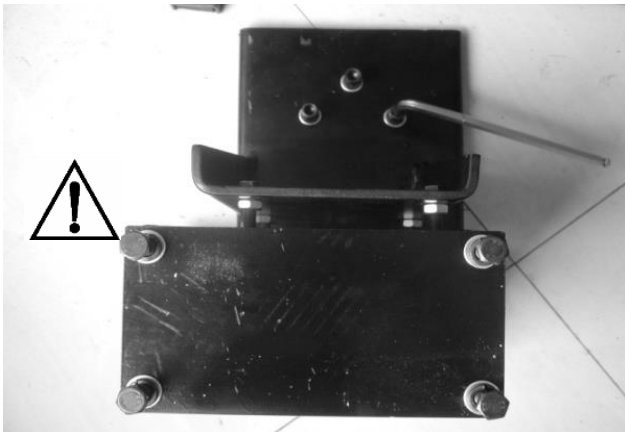

Fig 7-1

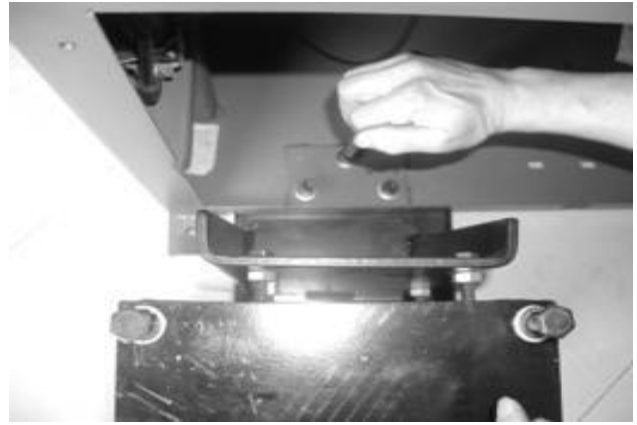

Fig 7-2

7.1.1 The left and right side of the base plate of body of the tire changer which can handle the tire with the diameter of more than 20" all have the installation hole for the left assistant prepared. Before installation, you can remove the side panel and take off the installation rubber plug. If there being the tool box, you should detach the tool box.

7.1.2 Detach the package of the PL330assistant. Check the accessory according to the pack list. After confirmation, takeout the base assembly(fig7-1) and install the screw and washer on it.

7.1.3 Push the platform of the base plate of the base assembly into the body through base plate on the left-back side of the body. Align the thread hole to the reinforce hole and use the bolt and washer to fix. (Fig7-2)

7.1.4 Install the body bracket (fig7-3A) on the seat assembly. Align. Use the screw removed before to fix and not tighten.

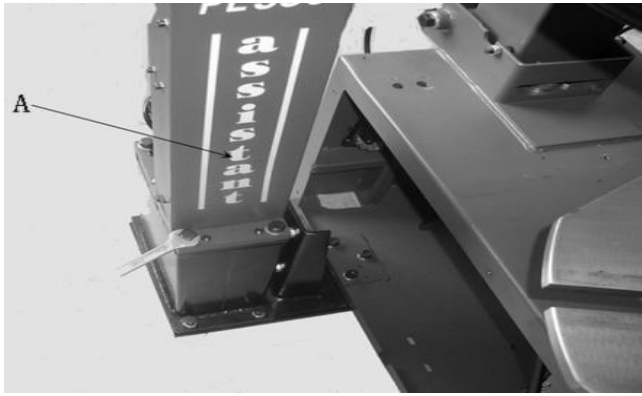

Fig 7-3

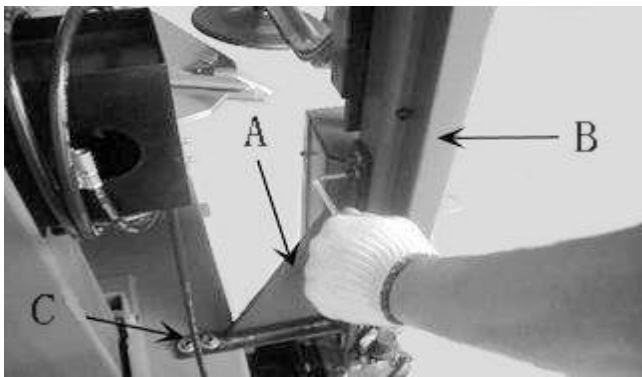

Fig 7-4

7.1.5 Use the fix supporting bracket (fig7-4A) to connect the body bracket and the body and insert the screw to fix.

7.1.6 Connect the air source hose (fig7-5A) and use Y Tee to connect the outlet hose and the other end connect with the inlet of the assistant pressure adjusting valve.

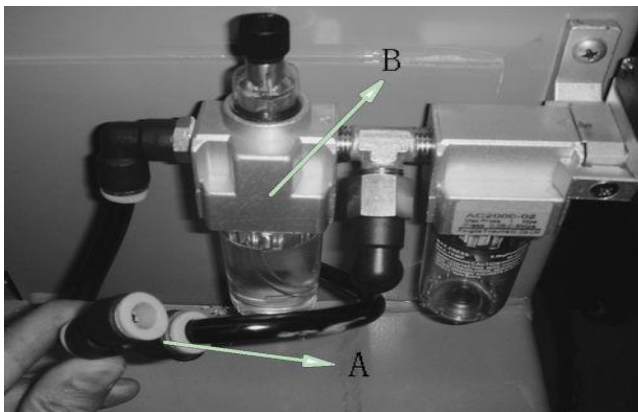

Fig 7-5

7.1.7 According to the fig36, fix the fix bracket on the

body and fix the tool box on the fix bracket and then use the lock nut to tight.

7.1.8 Loose the nut below the base and turn the screw clockwise until it against the ground and tight the nut.

(Fig 7-7)

At this moment, the installation of the left assistant completed.



Fig 7-6

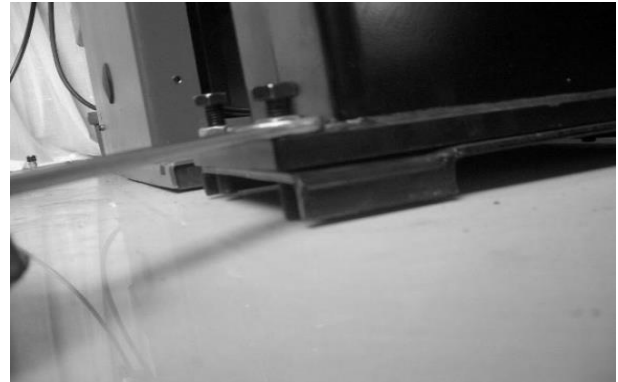

Fig 7-7

7.2 usage

7.2.1 After detach the tire from the rim according to the instruction of the chapter 5, we can execute the following operations.

7.2.2 First, position the claw according to the dimension of the tire and then clamp the rim by the claw and position the tire press cone roller at the center of the

rim(fig7-8) . Push down the manual valve to press down the rim until the external rim of the rim is lower than the surface of the claw. At this moment, you can immediately lock the rim. Lift up the support arm and place it at the working position and take off the press cone roller and place it on the support.



Fig 7-8

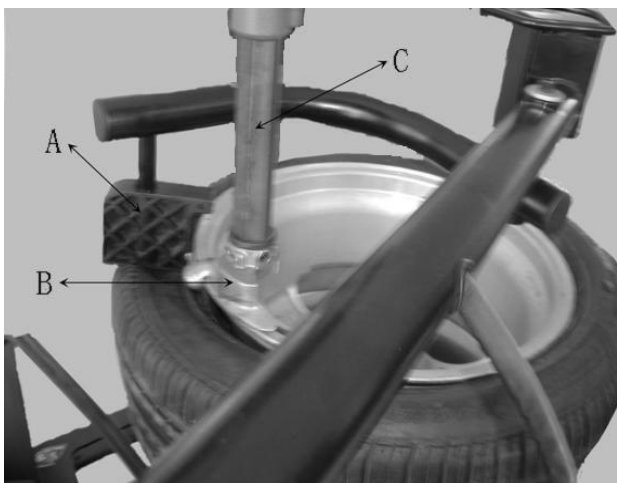

Fig 7-9

7. 2. 3 Use the press (fig7-9A) to press down the tire section by section rim detached from the mouth and use the brush to spread the lubricant on edge of the lip. Position the demount tool (fig7-9) in the demount position. Place the press beside of the demount tool to press down the lip and insert the crowbar below the

demount tool in between the rim and lip (fig7-10). Lift up the press and move it to the position opposite to the demount tool and press the lip into the tire detach groove and then rotate the crowbar to lift the lip onto the demount tool (fig7-11). Rotate the turntable to detach the upper lip.



Fig 7-10



Fig 7-11

7.2.4 Detach the lower lip: Use the disk to lift up the bottom of the tire from the bottom of the mouth (fig7-12) and detach the lower lip according to the step5.1.5.

7.2.5 MOUNT TIRE

First, according to the step (5.2.1) ~ (5.2.3) install the lower lip and use the press to press the lower lip as shown in the fig7-14. Rotate the turntable by about 90°. And then clamp the press in the demount tool (fig7-13) and continually rotate the turntable until the completion

of the operation.



	<p>Cut off the power supply and pneumatic source before any maintenance.</p>
---	--

Fig 7-12



Fig 7-13



Fig 7-14

Chapter8 Maintenance

8.1Note



The unauthorized personnel is prohibited to execute the maintenance.

The routine maintenance described in the manual is necessary to operate the machine correctly and prolong the life of the machine.

If not maintenance often, it will affect the operation and reliability of the machine and may cause the dangerous to the operators or the others near the dangerous area.

It must be the professional personnel to use the original parts to change the parts with fault.

It is prohibited to detach and modify the safety device (valves to limit or change the pressure)



We hereby state that the manufacturer will not hold any responsibility to the damage arising from the use of the spare parts supplied by the other manufacturers or modification of the safety device.

8.2 Maintenance

Weekly clean the turntable using the diesel oil avoiding the existing of the dust. Lubricated the clamping jaw guide rail.

Every 30days, execute the following operations:
 Check the oil level of the lubrication oil tank. If necessary, release the screw to fill in the oil in the oil tank (Fig 8-1) . Only use the oil of the viscosity ISO VG and grade ISOHG to lubricate the compressed air

route.

Check if it will fill one drop of oil when step the pedal for 3-4 times (Fig4-14-9), if not, use the top screw to adjust (Fig 8-1) .

20days after 1st time of use, retighten the clamping jaw tighten screw (Fig 23) If without force, check if the belt is loose. Detach the driven belt through the adjustment screw (Fig8-2) on the special motor rack.

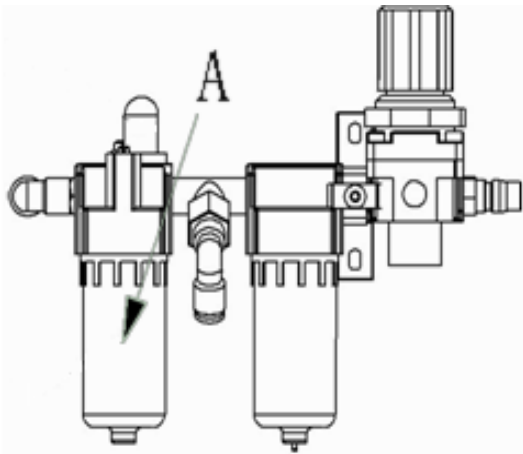

Fig 8-1

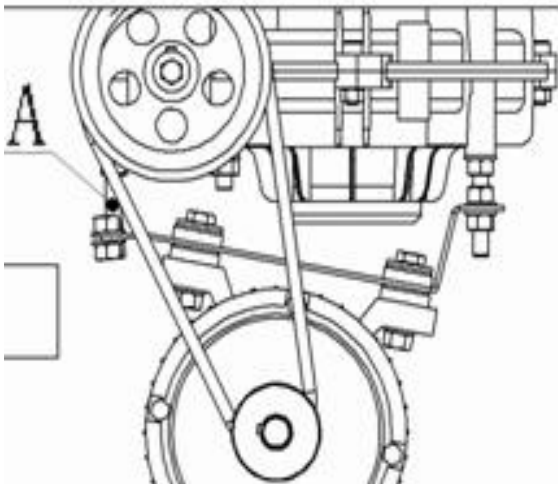

Fig 8-2

8.3 Clearance adjustment between tool head and rim

8.3.1 Adjust hexangular lock plate and lock clearance adjustment

When the hexangular shaft lock handle is released

downwards, the hexangular shaft rise under the effect of the spring. When the lock handle rotates clockwise by 100degree, the lock shaft connected with the handle will push up the lock plate to lock the hexangular shaft, meanwhile, the tool head will shift upwards and rightwards about 2mm to form the clearance to the rim, If it is not locked firmly of the clearance not correct, you can adjust by the adjust nut (Fig8-3):

·Adjust the adjustment nut at the front end of the hexangular lock plate downwards, the clearance will reduce;

·Adjust the adjustment nut at the front end of the hexangular lock plate upwards, the clearance will increase.

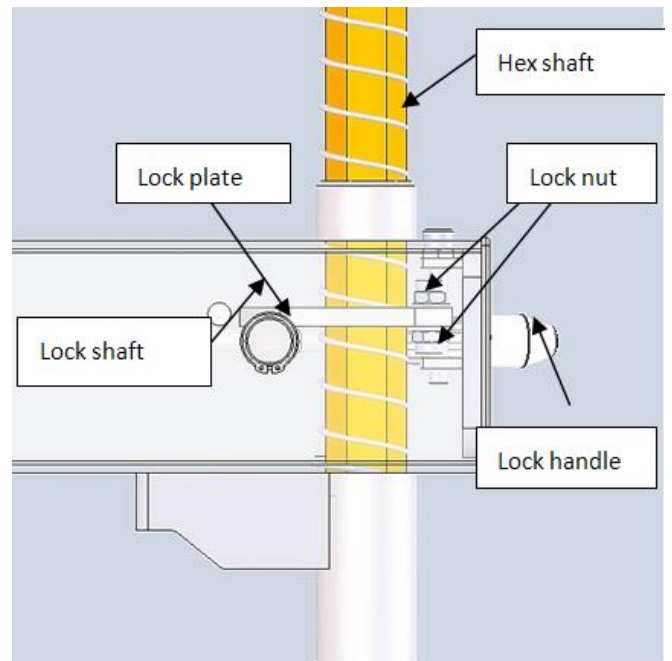
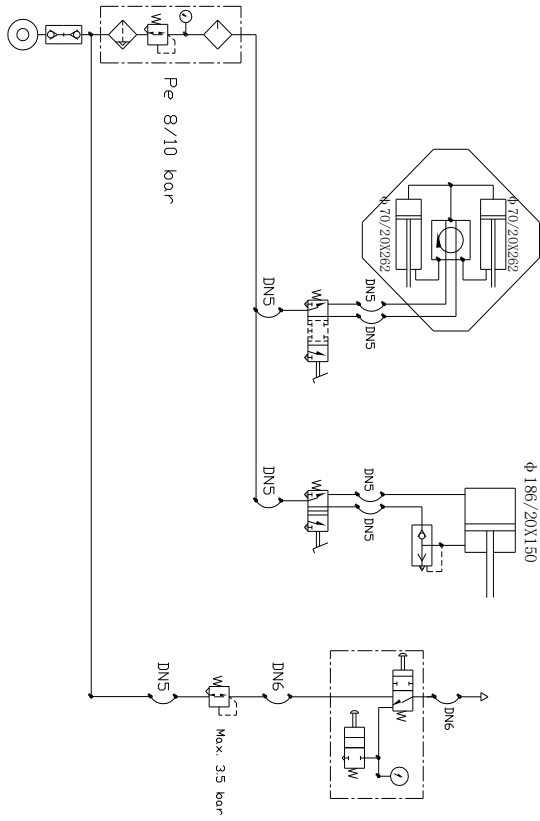

Fig 8-3

Pneumatic scheme

Semi-automatic pneumatic scheme



Semi-automatic burst inflation pneumatic scheme

