



AUTOMATIC WHEEL BALANCER

**Installation
Operation
Maintenance
JUNY-PHJ**

Manual





WARNING

- This manual is an integral part of this product, please read carefully to prevent any danger of misoperation!
- Keep this manual well for future further maintenance.
- This machine is only used for wheel balancing, not for other purposes.
- The manufacturer is not liable for damage caused by misuse or using for other purposes.

DO'S AND DONT'S

- The machine must be operated by specially trained and qualified personnel. Any modification of the machine parts and out of scope of use, without the permission of the manufacturer or the requirements of the manual, may cause direct or indirect damage to the machine.
- The balancing machine should be installed and fixed on smooth ground. Don't place it on wood floor! Otherwise the accuracy will be reduced easily!
- A distance of not less than 0.6m should be left between the back of the balancing machine and the wall to ensure good ventilation and heat dissipation. Note: leave enough space on the left and right side of the balancing machine to allow unrestricted operation.
- Do not keep the balancing machine in an extremely hot, extremely cold, or extremely humid environment. Avoid placing it next to heating equipment, faucet, air humidifier or stove, and avoid contacting with a lot of dust, ammonia, alcohol, thinner or spray adhesive.
- When operating, please use appropriate equipment and tools, and wear corresponding labor protection supplies, such as: work clothes, goggles, safety shoes.
- When the machine is working, please keep it away from the non-operator. Please be careful not to touch the moving parts with hands or other parts of the body when the balancing machine is working.

TABLE OF CONTENTS

1. overview-----	1
2. installation -----	2
3. machine introduction-----	3
4. operation -----	6
5. calibration -----	10
6. trouble description -----	11
7. trouble shooting-----	11
8. Parameter setting-----	12
9. OPT program-----	13
10. Product explode drawing -----	14

ONE. Overview

The poor dynamic balance of wheels will make the running wheels jump and the steering wheel vibrate, which will affect the driving experience, leading to increased gap of the joint part of the steering system, damage the shock absorber and steering parts, and increase the chance of traffic accidents. These problems can be avoided by performing the wheel balancing.

This type of wheel dynamic balancing machine adopts the new type of hardware system with large scale integrated circuit consisting of high speed information acquisition, processing and calculating. The machine is equipped with: ST motorcycle dedicated mode, DYN dynamic balance, ALU1 aluminum alloy, ALU2 aluminum alloy and ALU3 aluminum alloy free paste mode (total 6 kinds of mode) to balance all kinds of car wheel shape.

1. Technical indicator

- Max. wheel weight: 70kg / 154 lbs
- Motor power: 250w
- Voltage: AC 110V 60Hz Single phase
- Balance precision: $\pm 1g$
- Balance speed: about 200r/min
- 1 standard mode, 3 aluminum alloy balance mode, 1 motorcycle balance mode
- Balance cycle: 8s
- Rim diameter: 10"~24" (254mm~610mm)
- Space left at back: <240mm¹ / 9.5"
- Noise: less than 70db
- Net weight: 78kg / 171 lbs
- Packing size: 840 x 575 x 1150mm / 33" x 23" x 46"

2. Performance

- The balance block can be adhered at 12 o'clock or 9 o'clock under ALU mode.
- Various balance operation mode, it can realize balance block clipped and adhered.
- Automatic trouble diagnosis and protection function.
- It is suitable for a variety of rim of steel structure and the aluminum alloy structure.

3. Working environment

- environment temperature: -5~50℃
- altitude: ≤4000 meters
- relative humidity: ≤85%

TWO. installation

1.unpacking inspection

Check whether the parts are missing or damaged according to the packing list. If you have any questions, please contact the supplier in time. The list details are as follows:

No.	name	quantity
1	caliper	1
2	#1 cone	1
	#2 cone	1
	#3 cone	1
	#4 cone	1
3	quick nut	1
4	Lead screw	1
5	reverse positioning bowl(optional)	1
6	reverse positioning bowl cushion(optional)	1
7	balance hammer	1
8	100g balance lead	1

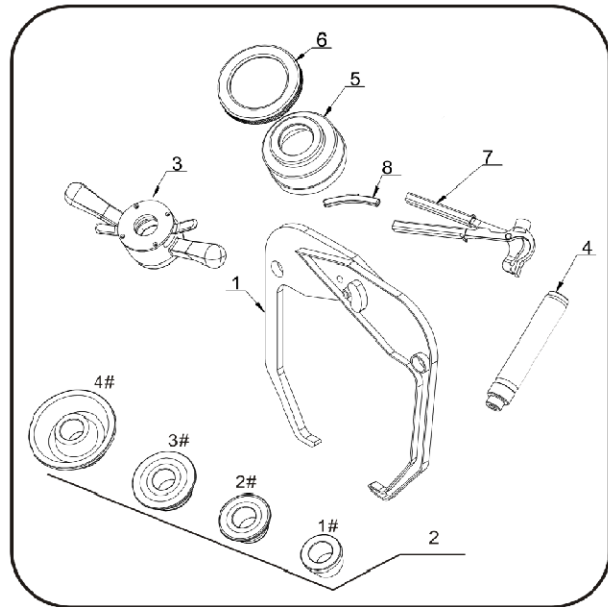

2.machine installation

The equipment must be installed on a solid cement floor or similar. If the ground is not solid, measurement error will be caused. There should be space left around the equipment for easy operation. See below:

3. The position of the mounting hole of the machine base should be fixed by expansion screw.

4. Main shaft lead screw installation

Install the lead screw on the main shaft, and tighten it (see below picture)

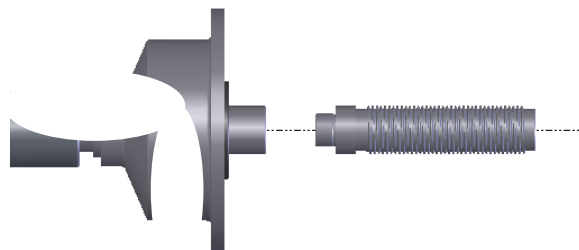

Note: when installing and removing the wheels, it is not allowed to slide wheel on main shaft lead screw to avoid scratches.



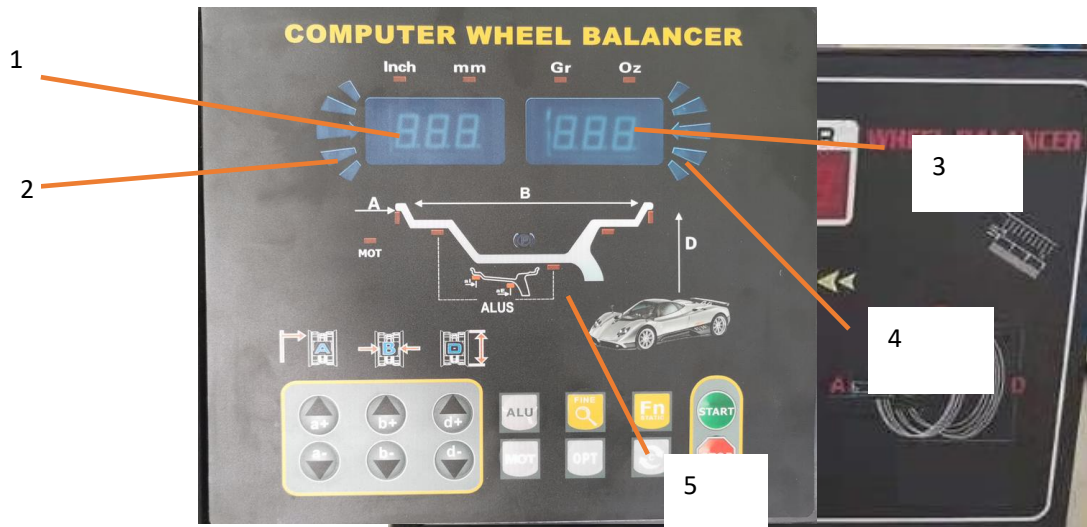







Display window (G)

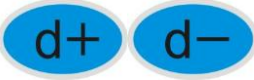

1. Display unbalance value inner
2. Display unbalance position indicator
3. Display unbalance value outer
4. Display unbalance position indicator
5. Balance mode indicator, it can realize the following balance mode:

figure	balance mode	operation method	explanation
 DYN	standard balance mode	<ol style="list-style-type: none"> 1. turn on the machine 2. input a,b,d value 3. start, wait until it stops 	The balancing weight is clipped on the two edges of the rim
 ALU1	ALU1 balance mode	<ol style="list-style-type: none"> 1. turn on the machine 3. input a,b,d value 4. Press the ALU key to turn on the mode light 5. start, wait until it stops 	The balancing weight is stuck on the inner and outer side plane of the rim
 ALU2	ALU2 balance mode	<ol style="list-style-type: none"> 1. turn on the machine 2. input a,b,d value 3. Press the ALU key to turn on the mode light 4. start, wait until it stops 	The balancing weight is stuck on the inner and middle plane of the rim
 ALU3	ALU3 balance mode	<ol style="list-style-type: none"> 1. turn on the machine 2. input a,b,d value 3. Press the ALU key to turn on the mode light. 4. start, wait until it stops. 	The balancing weight is clipped on edge of rim and is stuck on plane of the rim.
 ALU-S	ALUS balance mode	<ol style="list-style-type: none"> 1. turn on the machine 2. Press the ALU key to turn on the mode light 3. input①ai②ae③ d value 4. start,wait until it stops 	Stick the balancing weight on two chosen positions.

Press button function (H)

Icon	Function description	Icon	Function description
	distance caliper head to the inner rim		OPT program
	input wheel width		balance mode selection
	input rim diameter		combination/division
	recalculate the balance results		display actual unbalance value
	start		stop or cancel

FOUR. Operation

1. Standard balance mode

1) Install the wheel

- ★ Before perform any operation make sure to remove all counterweight. Check whether the tire pressure conform to specified value. Check if there is any deformation on rim surface and center hole. According to the wheel rim structure, select the appropriate wheel installation method. Choose the following two installation methods according to the wheel rim structure:



main shaft— (direction of the rim installation surface is inside) —
 suitable cone (small side inside) —quick nut

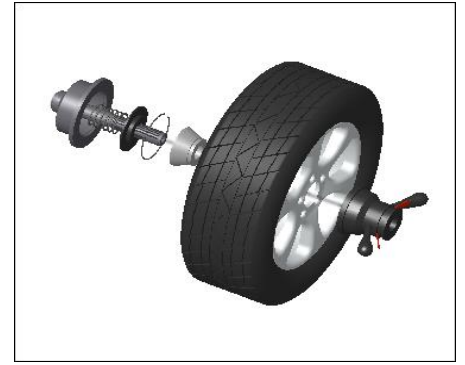

main shaft—tower spring (spring is installed inside shaft) -
 suitable cone (big side inside) —wheel—pressure cup-quick nut

Note: when install or remove the wheel,it is not allowed to slide the wheel on main shaft lead screw, to avoid any scratching.

- 2) turn on the power switch
- 3) input a b d value
 - distance (a) value: pull the scale to the position as in pic.1 and hold it for 4 seconds, read this value from measuring scale, and input the value manually through **a+** **a-**.
 - width (b) value: read it directly from the rim or measure it by equipped caliper as in pic.2, and input the value manually through **b+** **b-**
 - diameter (d) value: read it directly from the rim, and input the value manually through **d+** **d-**

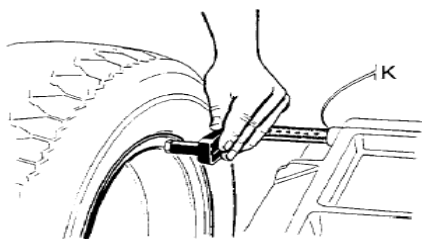

fig. 20b

Pic.1

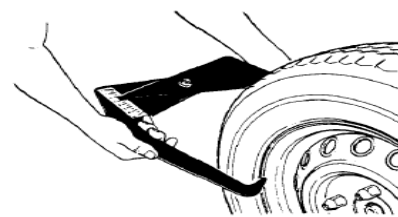
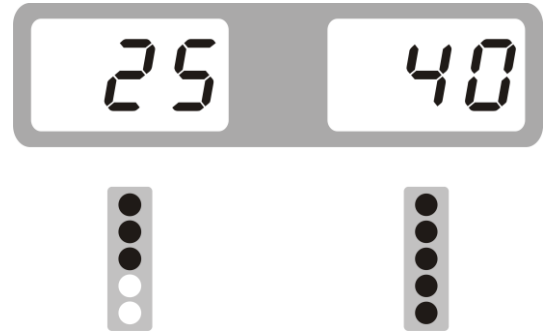
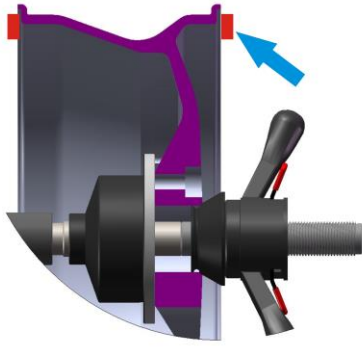

fig. 20a

Pic.2

- 4) put down the hood or press **START** key to rotate the wheel.
- 5) After the wheel stops, the digital tube displays unbalanced result, press **FINE** key to read actual unbalance weight.
- 6) Slowly rotate the wheel counter-clockwise by hand until the indicator light outer is all on. At this time, the highest point (12 o'clock) of the outer rim is the correct point of the unbalance. Add corresponding weight at this position. See Pic.3



Pic.3

7) Slowly rotate the wheel counter-clockwise by hand until the indicator light inner is all on. At this point, the highest point (12 o'clock) on the inner rim is the correct point of unbalance. Add corresponding weight at this position. See pic. 4

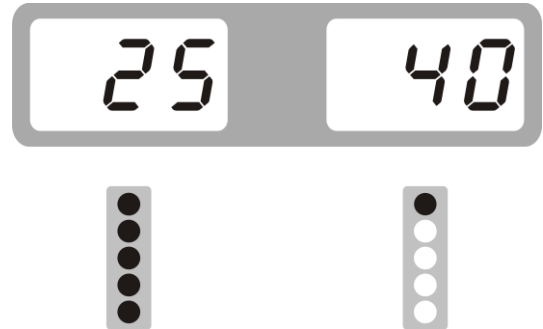
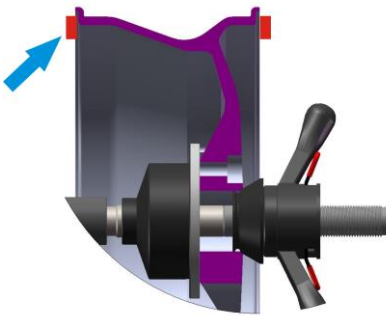

Pic.4

8) After the weight is all clipped on, press **START** key to rotate the wheel, if no mistake during operation, pic. 5 will be shown, which indicates that the dynamic balance is successful.



Pic.5

2. ALU-2 balance mode (stick weight on the rim)(ALU-1, ALU-3 are the same, only different position)

- 1) Please refer to the above mentioned way of measuring distance, width, diameter, three values.
- 2) According to structure of rim, press **ALU** key to choose ALU2.
- 3) Please lower down the hood or press **START** key to rotate the wheel.
- 4) After the wheel stops, the window display the unbalanced weight, press **FINE** key to check the actual unbalanced weight.
- 5) turn the wheel slowly anti-clockwise with the hand, until the outer imbalance indicator lights are turned on, at the 12 o'clock is the position for sticking imbalance weight. Weight placement positions are as shown in below pictures. Stick corresponding balance weight on the outer of the wheel rim. See pic.6.

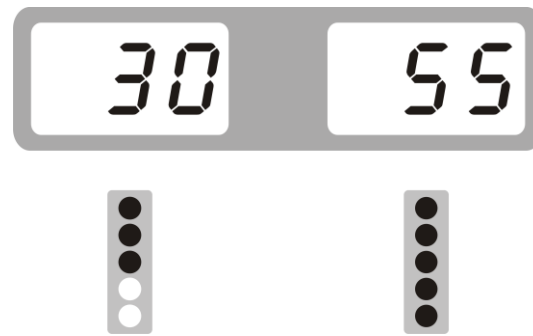
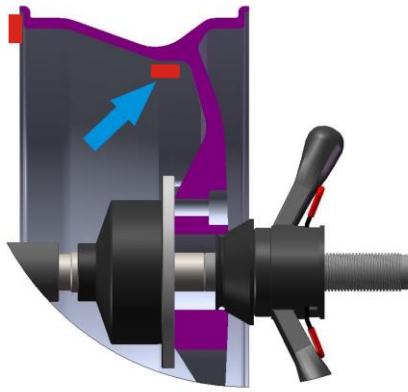

Pic.6

6) Turn slowly the wheel counter-clockwise, until the inner indicator lights are turned on, at the 12 o'clock is the unbalance position as shown in below pictures. Stick corresponding balance weight on the inside of the wheel rim. See pic.7.

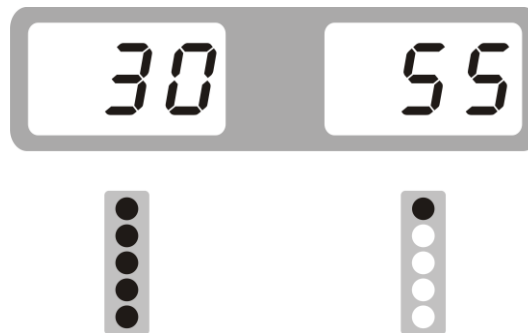
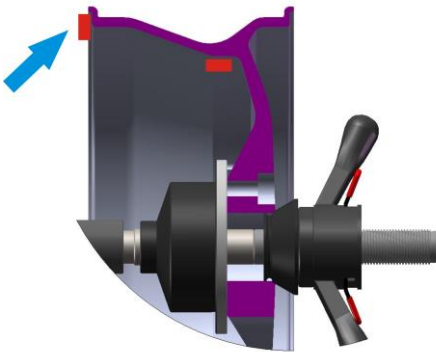

Pic.7

7) After placing the balanced weight, press **START** key to spin the wheel. If the operation is correct, we will see pic. 8. It indicates that the balancing was successful.



Pic.8

3. ALU—S balance mode (Optional function)

★This function is applicable to very special rims, and the normal alu-1 and alu-2 methods can't guarantee sufficient balance accuracy. Choose this balance mode.

1) Input al, aE, d value

- al distance value: Pull out the ruler head as it is shown in pic. 9 first and hold it at F1 position for 4 seconds, automatically read the "al distance" data from the measuring scale, and manually correct the data through **a+** **a-** (automatic measurement is optional).
- AE distance " value: pull out ruler head as it is shown in pic. 9 first and hold it at FE position for 4 seconds, and automatically read the "aE distance "data from the measurement scale, and manually correct the data through **b+** **b-** (automatic measurement is optional).
- diameter (d) value: automatically read it from the tire, input through **d+** **d-**

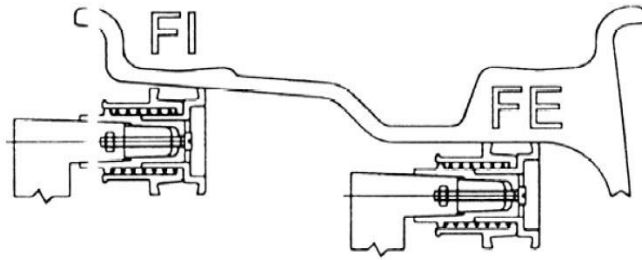

Pic.9

2) put down the hood and press **START** key, then the main shaft start to rotate

3) There are two ways to check the unbalanced result

3.1 set the option SLC to OFF.

3.2 Rotate slowly the tire anticlockwise by hand until the outer side of indicator lights are all on, at the point of 12 O'clock is the unbalance point of alignment plane. Balance alignment planes are as shown in below pictures. Paste corresponding balance weight on the outside of the wheel rim. See pic.10

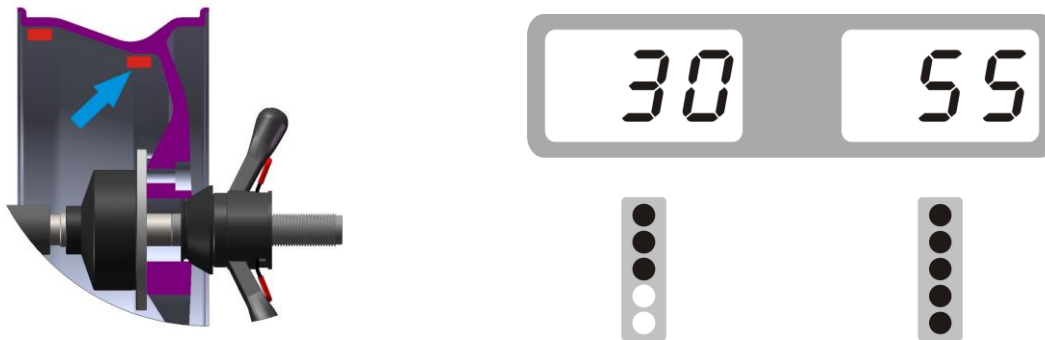

Pic.10

3.3 Rotate slowly the tire anticlockwise by hand until the inner side of indicator lights are all on, at the point of 12 o'clock is the unbalance point of alignment plane. Balance alignment planes are as shown in below pictures. Paste corresponding balance weight on the inside of the wheel rim. See pic.11

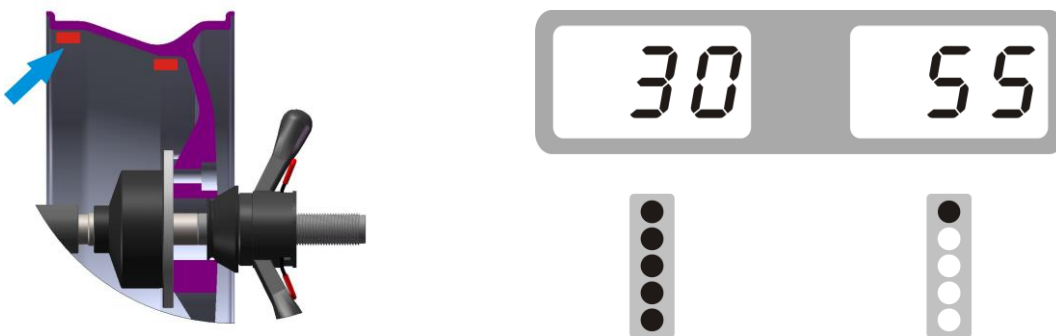

Pic.11

3.4 After placing the balanced lead, press **START** key to rotate the main shaft. If the operation is correct, we will see pic. 12. It indicates that the balancing is successful.



Pic.12

4.set the option SLC to ON (it is applicable for automatic measuring ruler)

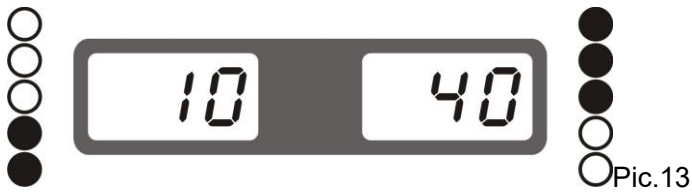

4.1 rotate slowly the tire anticlockwise by hand until the outside of indicator lights are all on (Pic.14),



4.2 Tear out the suitable weight lead(Pic.15) and place it on head of ruler (Pic.16),

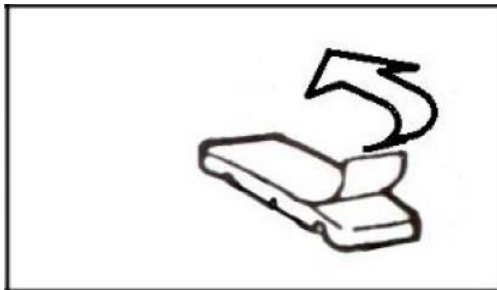

Pic.15

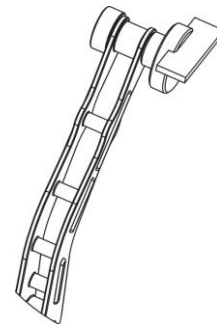

Pic.16

4.3 Pull out the ruler until to see the position of outer unbalance point on rim outside (Pic.17)

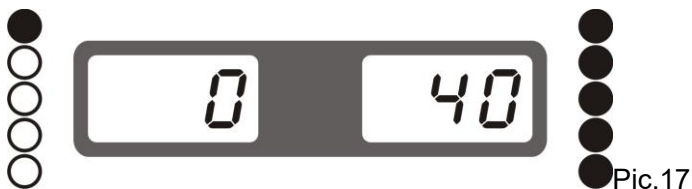

4.4 Paste the lead at the unbalanced point of outer rim, pic.18.

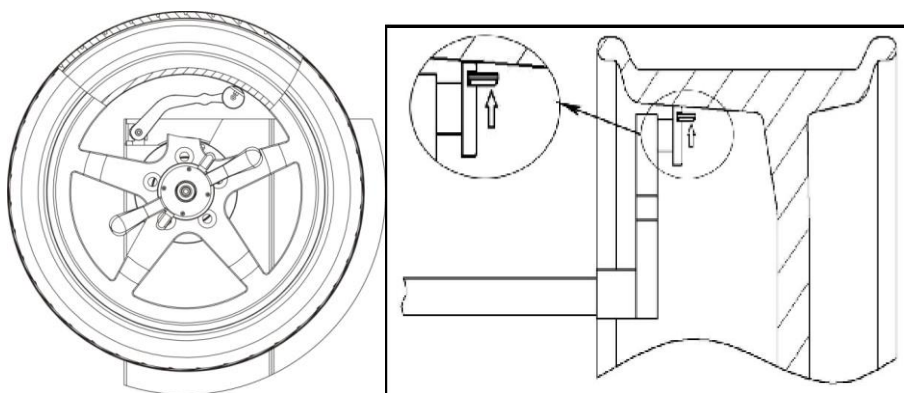

Pic.18

4.5 Rotate slowly the tire anticlockwise by hand until the inside of indicator lights are all on (Pic.19)

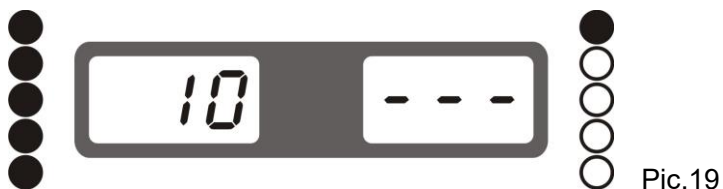

Pic.19

4.6 Tear out the suitable weight lead (Pic.15) and place it on head of ruler (Pic.16)), pull out the ruler until to see the position of inner unbalance point on rim inside (Pic.20)



Pic.20

4.7 Paste the weight lead on the tire, Pic.21

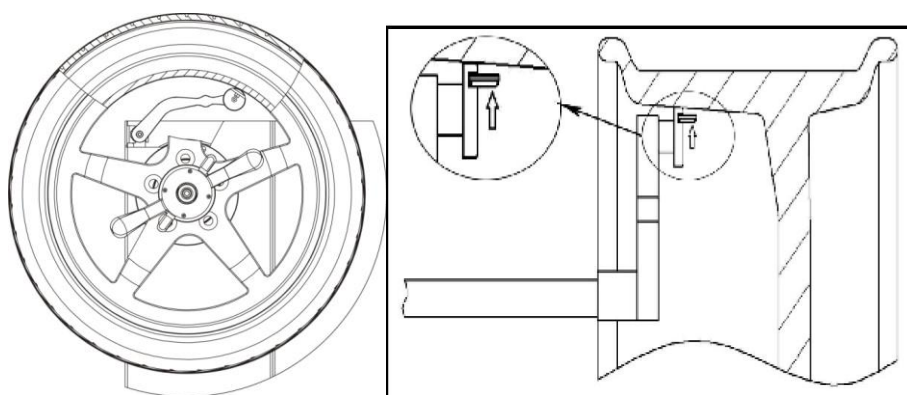

Pic.21

4.8 After placing the weight lead, press **START** key or put down the hood, pic.22 is shown. It indicates that the balancing is successful.



Pic.22

5.ALU—S balance split operation

1	In case of ALU-S mode unbalanced weight is come out, press F	display>	
2	Input quantity of spokes by d+ d- , then press F	display>	
3	Hold one of the spokes on the rim at 12 O'clock, then press F	display>	

4	Slowly turn the tire counterclockwise until the outer side of unbalanced SP1 indicator lights are all on (the unbalanced position is determined according to SLC setting before operation)	display>	
5	Slowly turn the tire counterclockwise until the outer side of unbalanced SP2 indicator lights are all on (the unbalanced position is determined according to SLC setting before operation)	display>	
6	Put down the hood, press key to rotate the main shaft, until it stops		
The operation is successful!			

FIVE. calibration

5.weight calibration



★Note: the self-calibration procedure should be run during initial installation, using or tested unbalanced weight is not accurate, to ensure the accuracy of the balancing machine (Note that the 100g balance weight used for self-calibration should be accurate, otherwise it is not correct about final result and directly affects the balance precision!)

5. 1 Power on and turn on the machine's power switch
5. 2 Install a medium size (13 "-18") tire which balance weight can be clipped on both inner and outer edge of rim, input rim dimension

1	Press and hold key, at the meanwhile press key	display >	
2	Put down the hood, press key to rotate the main shaft, wait until it stops	display >	
3	Open the hood, rotate the wheel to see outer indicator lights are all on, add 100 grams of balance weight at 12 o'clock and lower the hood, press key to spin main wheel, wait until it stops	display >	
4	Open the hood, rotate the wheel to see inner indicator lights are all on, add 100 grams of balance weight at 12 o'clock and lower the hood, press key to spin the wheel, wait until it stops.	display >	
Self-calibration is successful !			





6. Distance ruler calibration (optional function)

+	display >	
Pull out the ruler to zero position and press key to confirm	display >	

Pull out the ruler to 15 position and press  key to confirm	display >	
Self-calibration is successful!		



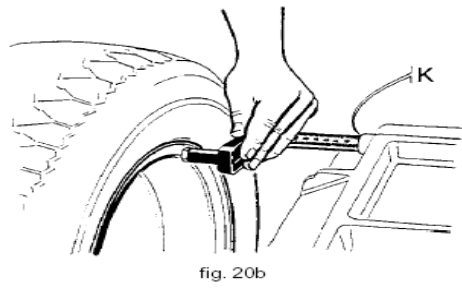

7. Diameter ruler calibration (optional function)

7. 1 install a tire and input the diameter by   (for example, if it is 14 inch, then input 14)

	display >	
Pull out the ruler to the rim of the tire and hold it	operate >	
Then press  key to confirm, which is indicating finished	display >	
Self-calibration is successful!		

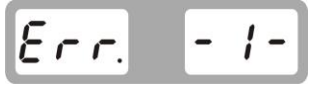
SIX. Trouble description

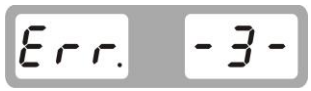
★When the machine shows the following faults, you should perform self-fault diagnosis and replace the damaged parts in time to ensure safe use!

No.	Screen displayed	Reasons	Solutions
1		1. No rotation. 2. With rotation.	1. Check or replace the power panel. 2. Check or replace the position sensor or computer panel. 3. Adjust holder of photoelectric panel
2		1. Tire is no fastened. 2. Position sensor.	1. Fasten the tire. 2. Check or replace position sensor.
3		1. Tire is with no pressure. 2. Tire distortion is out of range	1. Mounting the tire and inflate it. 2. Check the tire.
4		1. Position sensor is something wrong. 2. Computer panel is something wrong.	1. Check or replace position sensor 2. Check or replace computer panel.

5		<ol style="list-style-type: none"> Travel switch is something wrong. Computer panel is something wrong. 	<ol style="list-style-type: none"> Check or replace travel switch. Check or replace computer panel.
6		<ol style="list-style-type: none"> Power panel is something wrong. Computer panel is something wrong. 	<ol style="list-style-type: none"> Check or replace power panel. Check or replace computer panel.
7		<ol style="list-style-type: none"> Customer data lost. Computer panel is something wrong. 	<ol style="list-style-type: none"> Self-calibration again. Check or replace computer panel.
8		<ol style="list-style-type: none"> 100g lead not added after self-calibration. Computer panel is something wrong. Power panel is something wrong. 	<ol style="list-style-type: none"> Self-calibration again. Check or replace computer panel. Check or replace power panel.
9		<ol style="list-style-type: none"> Travel switch is something wrong. Computer panel is something wrong. 	<ol style="list-style-type: none"> Check or replace travel switch. Check or replace computer panel.
10		<ol style="list-style-type: none"> Computer panel is crashed. Power panel is something wrong. 	<ol style="list-style-type: none"> Check or replace computer panel. Check or replace power panel.

SEVEN. Trouble shooting

★In normal standby mode, press and at the same time to enter in, press key to perform next testing, press key to exit.

Test order	Screen displayed	Function name	Function normal definition
1		Testing start	All lights are on
2		Position sensor	Rotate main shaft, vary from 0-64
3		Distance ruler sensor (optional)	Value showed in window varies 327-335 when pull out the ruler
4		Diameter ruler sensor (optional)	Value showed in window varies 327-335 when rotate the ruler rod to the other direction
5		Width ruler sensor (optional)	Value showed in window varies 327-335 when rotate the ruler rod to the other direction
6		Pressure sensor	Value varies from 4X-4X to 6X-6X when you press the main shaft.

EIGHT. Parameter setup

1. Operation setup



★in normal standby mode, press key, at meanwhile press key to enter in, and are used for amending, key is for next item.

★The machine has the following functions, which can be adjusted according to your own requirements.

Function sequence	Screen displayed	Function definition	option

1		Unbalanced weight hidden	5/10/15
2		Prompt tone	open/closed
3		brightness	1-8 grade
4		Inch switch	Inch open/inch closed
5		ALU- to paste at 9 O'clock	ALU mode to paste at 12 O'clock/ ALU-mode to paste at 9 O'clock
6		ALU-S mode switch to paste at ruler head	OFF is to paste at 12 O'clock, ON is to paste at ruler head
7		Very small wheel operation	OFF/ON

2.Hood setup

★in normal standby mode, press , at mean time press  key, it will automatically switch between two states

★The machine has the following functions, which can be adjusted according to your own requirements.

Function sequence	Screen displayed	function	definition
1		hood	Put down hood to start
2		hood	Put down hood+  key to start

3. Weight unit setup

★in normal standy mode, press , at mean time press  key, it will automatically switch between two states.

★The machine has the following functions, which can be adjusted according to your own requirements.



Function sequence	Screen displayed	function	definition
1		Weight unit	Weight results show grams
2		Weight unit	Weight results show ounces

NINE. OPT program

* This function can be performed when the unbalance weight is too big or the rim is deformed *

Select the appropriate installation mode according to the rim shape and input rim data

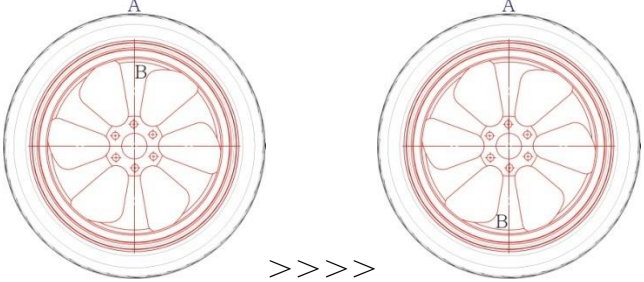
1	Press  key	display >	
---	---	--------------	--

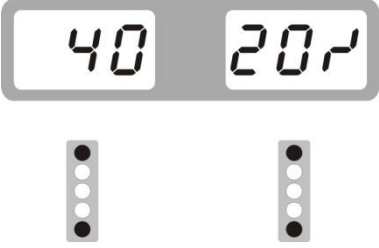
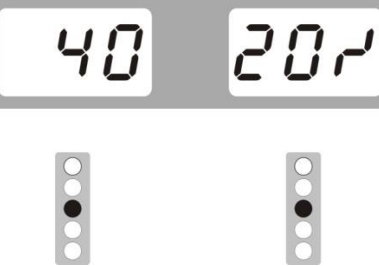
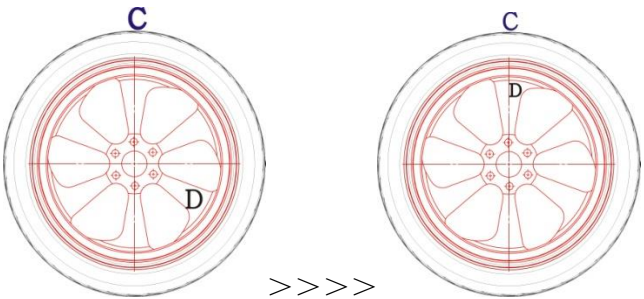
2	Put down the hood, press START key	display >	
3	Demount the tire from the rim and make a mark, then mount it again in the opposite position at 180 degree.	operate >	
4	When done, put down the hood, press START key	display >	
5	Find the rim C position and make a mark	display >	
6	Find the rim D position and make a mark	display >	
7	Make a mark at rim D and tire C, demount the tire from the rim and then mount it again to make these two points overlap with each other.	operate >	
8	When done, put down the hood, press START key	display >	Unbalanced weight is less than before is successful